

DIN Rail Mounted Dial-up Modem Users Manual

366-100

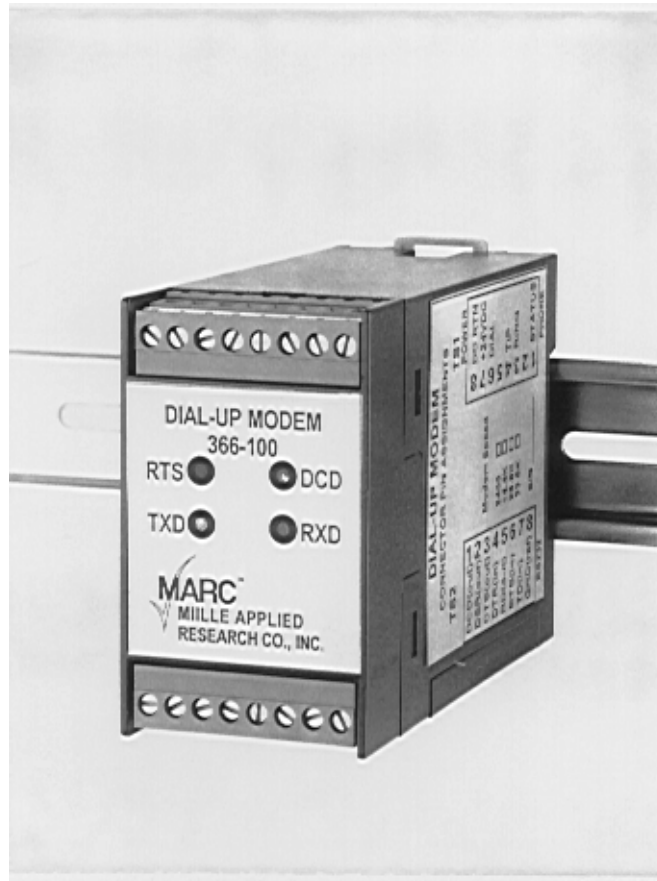

Copyright © 2002 Miille Applied Research Co., Inc.
Houston, Texas

This page is left blank intentionally

TABLE OF CONTENTS

1.1	General.....	1
1.2	Physical Description	1
1.3	Indicators.....	1
1.4	Specifications.....	2
	1.4.1 Physical.....	2
	1.4.2 Operating Environment.....	2
	1.4.3 Power Requirements	2
	1.4.4 LED Indicators.....	2
	1.4.5 Connections.....	2
	1.4.6 Operating Modes and Speeds.....	2
	1.4.7 Part Numbers	2
2.1	General.....	3
2.2	RS232 Connections.....	3
2.3	Phone Line Connections	3
2.4	Power Connections	3
2.5	Modem Control/Status.....	4
2.6	Options.....	6
2.7	Phone Number Storage.....	6
3.1	AT Command Format.....	7

Introduction

1.1 General

The Miille Applied Research Co., Inc. (MARC) Model 366-100 is a full-function DC powered dial-up modem that mounts on a standard DIN-rail and provides data communication with other Bell and CCITT compatible modems. The modem is FCC certified for direct connection to the dial-up Public Switched Telephone Network (PSTN). This modem provides convenient terminal compression screw hook-up and clearly marked, easily accessible switches for quick and accurate operating mode configuration. The modem is ideal for connecting a PLC or other intelligent device for remote programming or data collection.

1.2 Physical Description

The 366-100 is a small DIN-rail mountable unit just 1.75" wide, 3.0" high and 4.1" deep as shown in the photo below. It has two 8 position pluggable terminal strips for easy hook-up and a removable door for easy access to the configuration switches. Four LED indicators on the front panel provide easy monitoring of data communication activity.

1.3 Indicators

The 366-100 has four LED indicators mounted on the front panel. TXD and RXD LEDs light when the modem is sending or receiving data. The DCD LED will be on when the modem is successfully connected to another modem and the two modems have completed their initial training sequence and are ready to send and receive data. The RTS LED monitors the state of the RTS input.

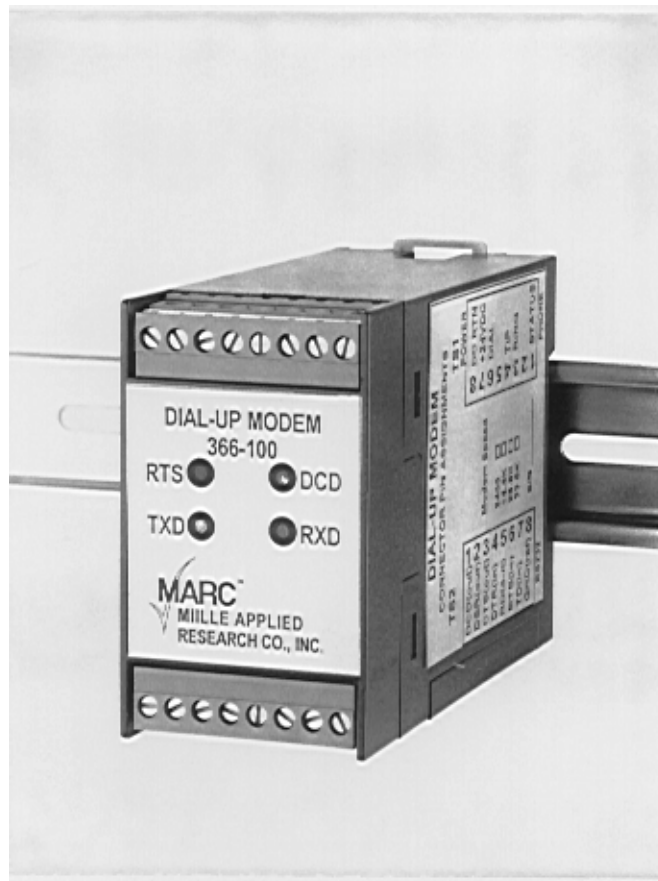

1.4 Specifications

1.4.1 Physical

DIN rail mountable unit 1.75”W X 3.0”H X 4.1”D

1.4.2 Operating Environment

0°to 60° Celsius

1.4.3 Power Requirements

24 VDC at 40 ma

1.4.4 LED Indicators

Provide status of the following signals TXD, RXD, DCD and RTS

1.4.5 Connections

Two 8-pin pluggable terminal strips.

1.4.6 Operating Modes and Speeds

Serial port speeds from 2400 baud to 38.4K baud depending on the model ordered. Serial port speed remains constant regardless of modem connect speed. Modulation/Demodulation standards V.34bis - 33,600bps V.34 - 28,800bps, V.32bis – 14,400bps and V.22bis – 2,400bps depending on the model ordered.

1.4.7 Part Numbers

366-100-024 2,400bps

366-100-144 14,400bps

366-100-288 28,800bps

366-100-336 33,600bps

Installation

2.1 General

The 366-100 modem is very easy to install and set up. Remove the modem from its protective antistatic bag and simply snap it onto a standard symmetrical EN 50 002 (35mm) mounting rail. If you need to remove the modem from the mounting rail use a flat screwdriver to retract the red mounting tab.

2.2 RS232 Connections

All RS232 signals are terminated on TS2, an 8 position pluggable terminal strip. TS2 is the terminal strip located on the side of the modem opposite the door. It is on the top of the case if the modem is mounted so that you can read the front label.

POSITION	SIGNAL NAME	DIRECTION
1	DCD	Output
2	DSR	Output
3	CTS	Output
4	DTR	Input
5	RDATA	Output
6	RTS	Input
7	TDATA	Input
8	GND	Reference

Table 1 TS2 Pin Assignments

2.3 Phone Line Connections

Telephone line connections are made TS1, the 8 position pluggable terminal strip located over the option door. It is on the bottom of the case if the modem is mounted so that you can read the front label. There are two wires to connect named Tip and Ring. These are the center two wires in a standard modular telephone cord. They are normally Red and Green in color. Connect the Red wire to Pin 5 and the Green wire to Pin 6. The modem does not provide a modular jack because it is used in harsh industrial environments where the standard RJ-11 modular jack is not reliable. If you require a modular connection, you should purchase a standard wall mount modular adapter available from any hardware store.

2.4 Power Connections

The modem is DC powered. The operating range is 18-36 VDC. You must pay particular attention to the input polarity. The modem will be damaged if the voltage polarity is reversed. Connect the Positive side of the DC supply to Pin 2 and the Negative side to Pin 1 on TS1

2.5 Modem Control/Status

The modem provides two control lines that can be used to monitor and control the modem using DC Inputs and DC outputs of a standard PLC for example. The Input is named “Dial” and the output is “Status”. The Dial Input is used to command the modem to go off hook and dial a previously stored telephone number. Connect the Dial input to the 24VDC return using a contact output from the PLC as shown on the simplified schematic below.

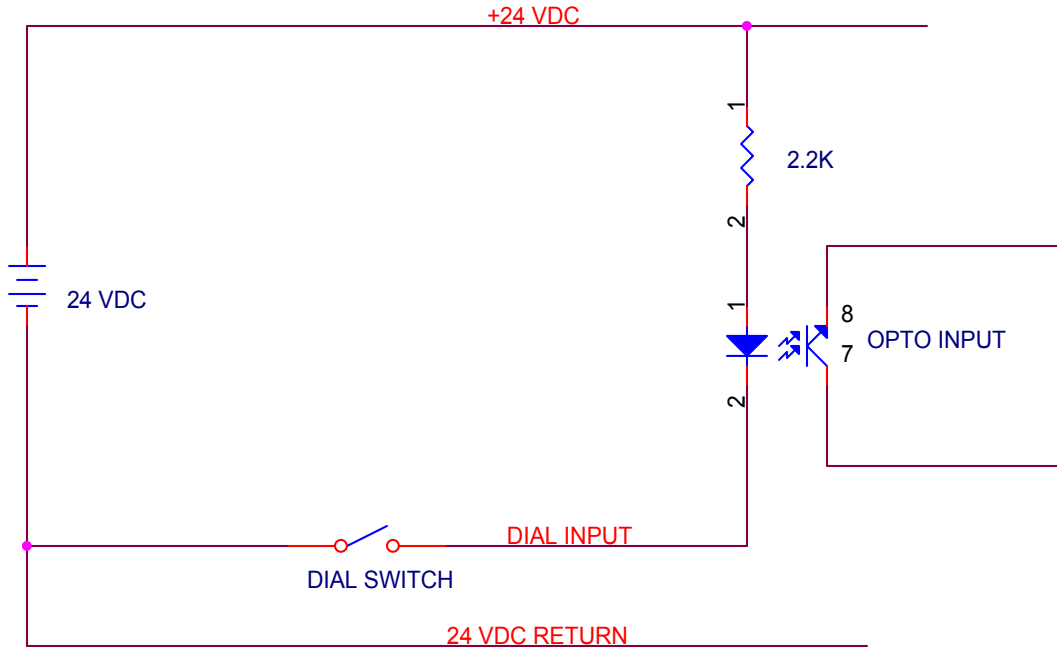

DIAL CONNECTION
SIMPLIFIED SCHEMATIC

Figure 1 Dial Input

The Status output will conduct to the 24VDC return when the modem is connected (DCD is ON). The status output is also optically isolated and will sink current when ON. A simplified schematic is shown below. Note that there is no internal current limiting resistor. An external current limiting resistor may be required. The opto isolator can sink a maximum of 20 ma.

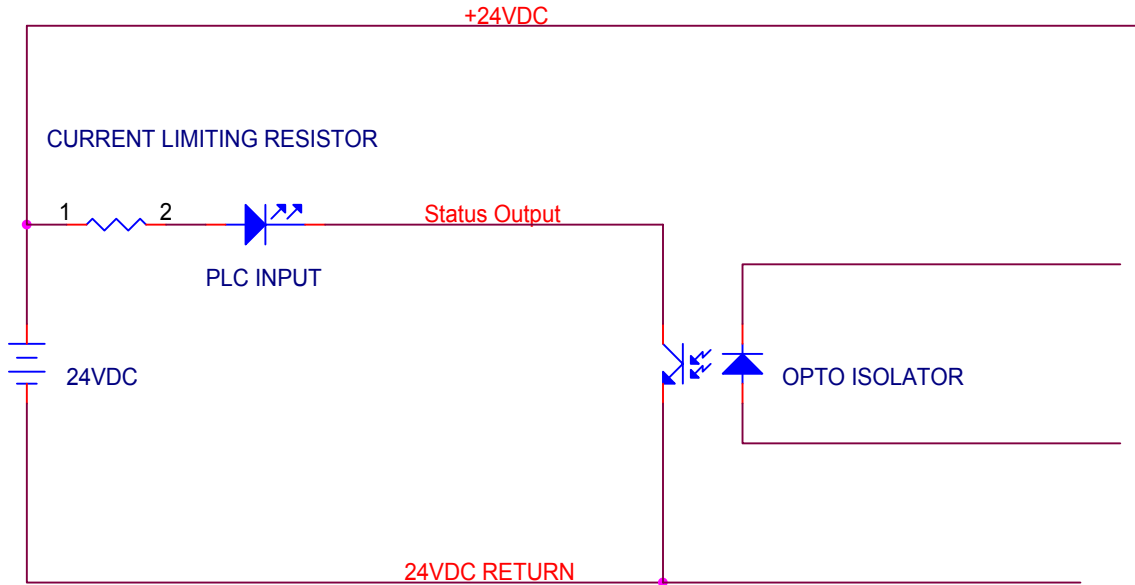

STATUS OUTPUT
SIMPLIFIED SCHEMATIC

Figure 2 Status Output

2.6 Options

Modem options are selected using a 9 position DIP switch. Remove the option door for access to this switch. The following table defines the option selections.

Position	Function	
1	DTR Dial Enable	0 Disable 1 Enable
2-3	Ring to Answer On	00 No Answer 01 1 st Ring 10 4 th Ring 11 8 th Ring
4-5	RS232 Port Speed	00 2400 baud 01 9600 baud 10 19.2K baud 11 38.4K baud
6-7	Max Modem Speed	00 Fast as possible 01 2400 baud 10 1200 baud 11 9600 baud
8	Modem Type	0 High Speed 1 Low Speed
9	Future	

Table 2 Modem Options

2.7 Phone Number Storage

The 366-100 can dial a phone number three different ways:

1. By sending the modem an ASCII string with the dialing information i.e. ATDT1234567(cr) where 1234567 is the number to dial.
2. Dial a previously stored number by changing the DTR input from OFF to ON if Option Switch 1 is ON
3. Dial a previously stored number by turning the DIAL input ON

To store a number for dialing by methods 2 or 3 above connect the modem to the serial port of a PC or other serial device and start a terminal emulation program such as Hyperterminal, Procom or FT. You can download FT from our website at <http://www.miille.com/ft.zip>. Enter a phone number using the &Z0 command i.e. ATZ0=1234567(cr) where 1234567 is the phone number to dial. Verify the phone number using the &V command. AT&V(cr) will show the current modem configuration and the phone number will be stored in the first location (0)

AT Commands

3.1 AT Command Format

The 366-100 modem factory default configuration is normally correct for most applications. For advanced users or special applications the factory configurations can be modified by sending AT commands to the modem. A command line is a string of characters sent from a serial port to the modem when the modem is in a command state (not connected to another modem). A command line has a prefix, a body and a terminator. Each command line must begin with the character sequence AT and must be terminated by a carriage return.

Characters within the command line are parsed as commands with associated parameter values. The basic commands consist of single ASCII characters or single characters preceded by a prefix character such as &, followed by a decimal parameter. The AT sequence may be followed by any number of commands in sequence except for commands Z, D or A. The maximum number of characters on any command line is 39.

For a complete list of the commands and a brief discussion of each, download the AT & S Register application note from our website <http://www.miille.com/AT&SREG.pdf>