

MILLE APPLIED RESEARCH CO., INC.

266-P00

DIN Rail Mounted

OMNII-COMM™

USERS MANUAL

October, 2003



This page is left blank intentionally

TABLE OF CONTENTS

USING THIS MANUAL 1

 1.1 OMNII-COMM™ FAMILY OVERVIEW 1

 1.2 MANUAL’S PURPOSE..... 1

GENERAL DESCRIPTION..... 2

 2.1 OBJECTIVES..... 2

 2.2 MODELS..... 2

 2.3 GENERAL FEATURES 2

 2.4 266-P00 SPECIFICATIONS 3

 2.5 PROTOCOL LIST..... 4

INSTALLATION..... 5

 3.1 OBJECTIVES..... 5

 3.2 UNPACKING AND INSPECTION 5

 3.3 AREA CLASSIFICATION NOTIFICATIONS 6

 3.4 CONNECTORS..... 7

 3.4.1 9-Pin “D” Connectors..... 7

 3.4.2 Pluggable Terminal Strips 8

 3.4.3 Power and P5 Connectors 8

 3.4.4 DC Power Connection..... 9

 3.5 RESET BUTTON..... 9

 3.6 FRONT PANEL LEDS..... 9

 3.7 JUMPER SETTINGS 10

 3.7.1 Opening the Omnii-Comm™ Case..... 10

 3.7.2 RS232/RS422/RS485 Selection 10

 3.7.3 RS422 Jumper Options 11

 3.7.4 RS485 Jumper Options 11

 3.7.5 Reset Switch Operation..... 12

 3.8 CONNECTOR PIN OUTS 12

 3.8.1 9-Pin “D” Serial Port Connector Pin Assignments 13

 3.8.2 “Pluggable” Serial Port Terminal Strip Pin Assignments 14

CONFIGURATION 15

 4.1 GETTING STARTED..... 15

 4.2 SYSTEM REQUIREMENTS..... 15

 4.3 INSTALLING OMNII-CONFIG™ 15

 4.4 UNINSTALLING OMNII-CONFIG..... 16

 4.5 STARTING OMNII-CONFIG 16

 4.6 BASIC PROCEDURE..... 17

 4.6.1 The three basic steps are: 17

 4.7 EDIT/CONNECTOR..... 17

 4.8 EDIT/GENERAL 20

 4.8.1 Edit/General/Database Protocol 20

 4.8.2 Edit/General/RTU Address 20

 4.8.3 Edit/General/Omnii-Comm™ Address 20

 4.8.4 Edit/General/Poll Timer Multiplier 21

 4.8.5 Edit/General/Radio Key Address..... 21

 4.8.6 Edit/General/Mode 21

 4.8.7 Edit/General/VRTU Equipped™..... 21

 4.8.8 Edit/General/Timer Table Type..... 22

4.8.9 Edit/General/Error Time Out	22
4.9 EDIT/POLL TABLE	23
4.9.1 Poll Table #1; Read Modbus Data from AB	24
Poll Table #1, Write	26
Poll Table #1, Error	27
4.10 SAVE CONFIGURATION	27
4.11 DOWNLOAD CONFIGURATION	28
4.12 CONFIGURATION DOWNLOAD	29
4.12.1 Connect/Check Connectivity	30
4.12.2 Connect/Setup	31
4.12.3 Control	32
4.12.3.1 Send Configuration to RAM	33
4.12.3.2 Upload Configuration to File	33
4.12.3.3 Transfer File from RAM to EEPROM	33
4.12.3.4 Transfer File from RAM to Serial EEPROM	34
4.12.3.5 Make RAM Active	34
4.12.3.6 Make EEPROM Active	34
4.12.3.7 Start Polling	34
4.12.3.8 Stop Polling	34
4.12.4 Mode	34
4.12.5 Clear	34
OMNII-COMM™ TROUBLE SHOOTING TIPS.....	35
5.1 PROBLEMS & SOLUTIONS	35
ERROR CODE DEFINITIONS.....	36
6.1 OBJECTIVES.....	36
6.2 GENERAL INFORMATION.....	36
6.3 PROTOCOL NUMBERS.....	37
6.4 OMNII-COMM™ ERROR CODES	39
6.4.1 Error Codes 10 – 1F Table Initialization Errors.....	39
6.4.2 Error Codes 20 – 2F Spurious Interrupt Errors.....	39
6.4.3 Error Codes 30 – 3F Port/Driver Initialization Errors	40
6.4.4 Error Codes 40 – 4F Modem Errors	40
6.4.5 Error Codes 50 – 5F Miscellaneous Errors	41
6.4.6 Error Codes 70 – 7F Driver I/O Errors	41
6.4.7 Error Codes 80 – 8F Floating Point Errors	42
6.4.8 Error Codes F0 - FF System Errors.....	42

USING THIS MANUAL

1.1 OMNII-COMM™ FAMILY OVERVIEW

The MARC Omnii-Comm™ is a microprocessor-based, multi-port, user configurable, serial communications module. The Omnii-Comm™ provides Protocol Conversion, Polling Master and Data Concentration functionality in a wide range of industrial communication applications. There are several models in the Omnii-Comm™ family of products. This Users Manual is specifically for our DIN rail mounted Omnii-Comm™ product PN 266-P00-XYZ. Other models are available for direct mounting in Allen-Bradley PLC 5 and SLC 500 Programmable Logic Controllers (PLCs). A single slot module for the Reliance Automate PLC is also available. Stand-alone units for 19" rack mounting are available for use in applications with other PLCs or when a PLC is not required.

The single slot PLC modules connect to the PLC back plane for +5V power only. All communication to the PLC takes place over a standard serial communication port, using the native protocol of the PLC. The stand-alone units such as the DIN rail mounted unit described in this manual are available with either a universal input AC supply or a 24VDC supply. A 12VDC option is also available: Please contact the factory or the product data sheet for order information. Some Omnii-Comm™ models support optional on-board leased line and/or dial-up modems that can provide extended communication capability for use over telephone lines, dedicated twisted pair wiring or radio networks. The DIN Rail unit described in this manual does NOT have internal modem capability. It DOES support external modem connections.

Each port of the Omnii-Comm™ is user configurable for protocol, communication parameters (baud rate, number of data bits, etc.) and for Master or Slave emulation as well as many other protocol specific parameters. The configuration software runs on any standard PC and is shipped with each module at no extra charge. No PLC programming is required.

1.2 MANUAL'S PURPOSE

This manual is specifically addressed to users of the MARC 266-P00-XYZ DIN Rail mounted Omnii-Comm™. If you need information on our other Omnii-Comm™ products please check on our web site at the following URL <http://www.miille.com> for the Users Manual for your specific product.

This manual covers the following areas:

- ❑ **Installation of the Omnii-Comm™**
- ❑ **Hardware Options**
- ❑ **Hardware Specifications**
- ❑ **Configuration Procedure**
- ❑ **Troubleshooting Tips**
- ❑ **Error Codes**

NOTE: WHEN THE NAME "OMNII-COMM™" IS USED IN THIS MANUAL, IT REFERS SPECIFICALLY TO THE 266-P00-XYZ DIN RAIL MOUNTED OMNII-COMM™ MODEL ONLY. PLEASE REFER TO OUR OTHER USERS MANUALS FOR DETAILS ON OTHER OMNII-COMM™ MODEL NUMBERS

GENERAL DESCRIPTION

2.1 OBJECTIVES

This section discusses the various models of the OMNII-COMM™. After finishing this section the reader should:

- ❑ Understand the basic features and functions of the Omnii-Comm™
- ❑ Be able to identify the part number series for each member of the Omnii-Comm™ Family

2.2 MODELS

The following listed models are all members of the OMNII-COMM™ family:

- ❑ **266-P00-XYZ** **DIN Rail Mounted Omnii-Comm™ (Described in this manual)**
- ❑ **166-500-XYZ** **Omnii-Comm™ for the PLC-5 processor**
- ❑ **166-20X** **Omnii-Comm™ for the SLC 500**
- ❑ **266-001-XYZ** **19" rack mounted Omnii-Comm™, 24 VDC Powered**
- ❑ **266-002-XYZ** **19" rack mounted Omnii-Comm™, 120 VAC Powered**
- ❑ **224-011-XYZ** **Omnii-Comm™ for Reliance Automate PLCs**

2.3 GENERAL FEATURES

The 266-P00-XYZ Omnii-Comm™ is a stand-alone DIN rail mounted unit that can be used with any PLC or even without a PLC in many applications. The "P" in the part number is a number that specifies the number of serial ports that the module is equipped with at the time of shipment. You can order this module equipped with from 2 to 5 serial ports (P=2, 3, 4 or 5).

Note: Two port modules have some significant restrictions. Please read carefully. One port on the Omnii-Comm™ is always required for configuration. When the module is started, this port may be re-configured as an active protocol port. It is highly desirable to keep a communications port available as a debug and diagnostics port when the module is running. Therefore, we highly recommend a 3 port unit as a minimum configuration.

The X in this part number selects the input power requirements. A "1" in this position selects AC power (100-240 VAC), a "2" selects 24 VDC and a "3" 12 VDC. The Y in the part number is used to select the type of connectors for the serial ports P1 through P4. Connector P5, the Default Configuration Connector, is always a 9-pin "D". A "1" in the Y position selects 9-pin "D" connectors for P1 through P4 and a "2" selects pluggable terminal strips for Connectors P1 through P4. The Z configuration option is reserved for future use and is always 0.

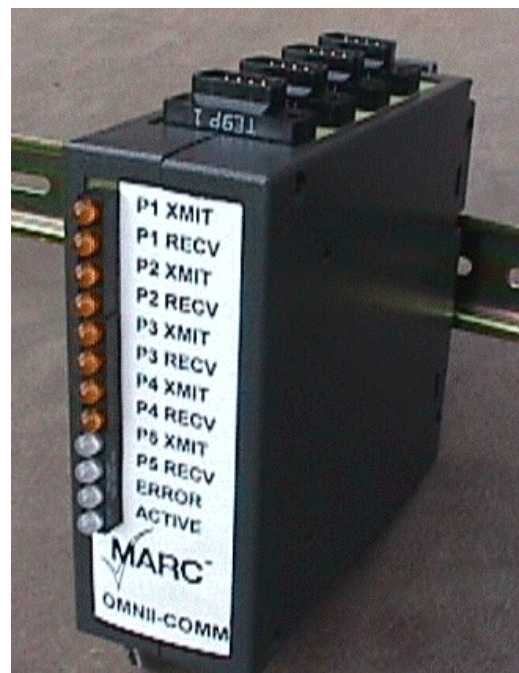

2.4 266-P00 Specifications

Specifications	
<p>Physical DIN rail mountable unit 1.75"W x 5.5"H x 5.75"D</p> <p>Power Requirements AC power 90 to 270 VAC 1 Watt* DC power 24 VDC 40 ma* DC power 12 VDC 80 ma* * maximum operating power for a 5-port unit</p> <p>Operating Environment 0° to 60° Celsius, 10% to 90% relative humidity</p> <p>LED Indicators Provide status of the following signals: TXD and RXD for each port plus ERROR and ACTIVE</p> <p>Protocols Supported (partial list) MODBUS Master and Slave, RTU and ASCII options 32-bit and "string by flow" data types permitted Teledyne/Control Applications (CA), both standard and Report by Exception Allen-Bradley DF1 Full-Duplex and Half-Duplex with PLC 2, PLC 5, PLC5/250 and SLC 500 addressing Square D SY/MAX Point-to-Point and Multidrop Omron Host Link Caterpillar CCM and DVR Custom Protocols available, contact factory for pricing</p>	<p>I/O Ports Maximum of 5 asynchronous serial data ports 1 Universal Serial Data Port, sync.or async.300 to 9600 baud (in place of one async port) 1 Config/Diagnostic port (can be used as a protocol port at run time) 4 ports have all modem control lines (RTS, CTS, DCD, DTR and DSR), 1 port with RTS/CTS only</p> <p>Serial Port Connections Connector P1 to P4: 9-pin "D" connector (male) or 9-pin pluggable terminal strips RS232 1-DCD(in), 2-RXD(in), 3-TXD(out), 4-DTR(out) 5-GND, 6DSR(in), 7-RTS(out), 8cts(in), 9-No Conn RS422 1and 3 TXD+ (out), 2 and 4 TXD-(out), 5-GND, 6 and 8 RXD+ (in), 7 and 9 RXD-(in)* RS485 1,3,6,8 TRD+, 2,4,7,9 TRD-,5-GRD* *User selectable term. and pull-up/down resistors</p> <p>Order Information 266-200-XYZ 2 serial ports 266-300-XYZ 3 serial ports 266-400-XYZ 4 serial ports 266-500-XYZ 5 serial ports X=1 for AC, 2 for 24VDC or 3 for 12 VDC Y=1 for 9-Pin "D" connectors, 2 for terminal stripsZ=0 Z= Z =0 Reserved for future use</p>

2.5 PROTOCOL LIST

The Omnii-Comm™ product is unique in that it supports a large number of different communication protocols. All the protocols are available in every unit. You select the ones you want to use when the module is configured. The following table lists the protocols available at the time this manual was written. The list is constantly expanding. Please see the Current Protocol List on our web site for a current list.

NAME	TOKEN	MASTER	SLAVE	COMMENTS
Local Ram	08 [08h]			Read/Write Local Ram (Omnii-Comm internal RAM)
Modem	09 [09h]			Dial-Up Modem
Data Base	10 [0Ah]			Read/Write internal Data Base
MODBUS	11 [0Bh]	X	X	Standard MODBUS (ASCII and RTU) with 32 bit support
A-B DF-1 F/D	12 [0Ch]	X		Allen-Bradley DF-1 Full Duplex
Square D	13 [0Dh]	X	X	Square D Sy/Max Point to Point and Multidrop Protocol
MARC	14 [0Eh]			MARC "universal" protocol
Teledyne/CA	15 [0Fh]		X	Teledyne/Control Applications Protocol
Configuration	16 [10h]	X		Debug/Diagnostic Protocol
Reliance	17 [11h]	X		Reliance Protocol
A-B DF-1 H/D	18 [12h]	X [R2]	X [R24]	Allen-Bradley DF-1 Half Duplex
OMRON	19 [13h]	X		Omron Host Link Protocol
ACM 3720	20 [14h]	X		PML ACM3720 Power Monitor
AD2150	21 [15h]	X		American Dynamics Matrix Switch
DUKANE	22 [16h]		X	Dukane
Caterpillar	23 [17h]		X	Caterpillar (use New Cat)
Caterpillar - New Cat	23 [17h]		X	Caterpillar (use instead of Caterpillar)
Dynalco TM5000	24 [18h]	X		Dynalco TM5000 Protocol
Dyn. TEC9000	25 [19h]	X		Dynalco TM9000 Protocol
Caterpillar DVR	26 [1Ah]	X		Caterpillar Digital Voltage Regulator
Conitel 2020 Slave	27 [1Bh]		X	L & N Conitel Slave Protocol
TEJAS V Slave	28 [1Ch]		X [R17]	Tejas Series 3 and 5 slave protocols
GE Lighting	29 [1Dh]		X	GE Programmable Lighting Controller
Modbus RBX	30 [1Eh]		X	Modbus Report-by-Exception (Radio)
Danload	31 [1Fh]	X		Danload 6000
ASCII	32 [20h]	X		Generic ASCII Protocol
Controlotron	33 [21h]	X		Controlotron System 990 Flow Display Computer
Tennessee Gas Pipeline	34 [22h]	X		Tenneco Gas TGP Protocol
Data Aire	35 [23h]	X		Data Aire Poll and Response Protocol
Liebert	36 [24h]	X		Liebert Protocol
CDC 44-560	37 [25h]		X	CDC Type II protocol
Multiport Monitor	38 [26h]	X		Substitute for Configuration/DEBUG in MultiPort hardware
SUTRON	39 [27h]	X		
SCI CSNet	40 [28h]		X	SCI Technology CSNet Protocol
Sullair Supervisor II	41 [29h]	X		Sullair Supervisor II protocol
Brite (BIF)	42 [2Ah]	X		
AMOCAMS 500	43 [2Bh]	X		Bristol Babcock AMOCAMS 500 protocol
Toshiba PLC	44 [2Ch]	X		Toshiba PLC "Computer Link" and "Transmission Control"
HSQ MISERnet	45 [2Dh]	X		
Colonial DLE	46 [2Eh]		X	
CA Satellite 4-byte	47 [2Fh]		X	CA Satellite with 4-byte meters
Quantum	48 [30h]		X	
CA Master	49 [31h]	X		
Sullaire Supervisor IE	50 [32h]	X		
Johnson Controls N2	51 [33h]		X	
Caterpillar M5X	52 [34h]	X		Can replace CAT
CA Satellite 3-byte	53 [35h]		X	CA Satellite with 3-byte meters
TEJAS V Master	54 [36h]	X [R28]		Tejas Series 3 and 5 master protocols
Conitel 2020 Master	55 [37h]	X		L & N Conitel Master Protocol
MODBUS 16 bit	56 [38h]	X	X	Standard MODBUS (ASCII and RTU) no 32 bit support
ENRON	57 [39h]	X	X	ENRON version of MODBUS protocol
GE SNP	58 [3Ah]	X		GE Series Ninety Protocol
Releases after Rev. 29 make use of paged RAM and require 128Kx8 RAMs, and may require new Gate Array chips (SLC version)				
Release 42 and beyond require version 5 of CONFIG due to differences in protocol tokens.				

INSTALLATION

3.1 OBJECTIVES

This section describes the procedures for installing the Omnii-Comm™ module. LED indicators, power and serial port connectors are identified and hardware selectable options reviewed. After reading this section, you should be ready to:

- ❑ **identify all of the connectors on the Omnii-Comm™**
- ❑ **set all user selectable jumper options of the Omnii-Comm™.**

3.2 UNPACKING AND INSPECTION

The 266-P00 Omnii-Comm™ is shipped in a specially designed shipping container. Open the box carefully and remove and inspect each item carefully. If any items are missing or damaged please contact Miille Applied Research Co., Inc. immediately. Each box should contain the following items:

- ❑ **Omnii-Comm™ (sealed in antistatic plastic bag)**
- ❑ **Users Manual (this manual)**
- ❑ **Omnii-Config™ CD If the CD is missing you can download the current Omnii-Config program from our web site at this URL <http://www.miille.com/Omnii-Config Setup.exe>**
- ❑ **Warranty Card**
- ❑ **AC power cord with 3 position power connector (AC Powered units only)**
- ❑ **2 position DC Power Connector (DC Powered units only)**

Carefully remove the Omnii-Comm™ from the antistatic bag and identify the connectors, reset button, and front panel LEDs as described in Sections 3.4 thru 3.6 below. It is recommended that you return the Omnii-Comm™ to the antistatic bag and shipping box for storage and transport until final installation is complete.

Next review jumper settings and change as required for your application as described in Section 3.7.

Plan your cable connections using the connector pinouts detailed in Section 3.8.

3.3 AREA CLASSIFICATION NOTIFICATIONS

This equipment has been certified for use in hazardous locations. It is extremely important that you comply with the following statements:

- A. *This equipment is suitable for use in Class I, Division 2, Groups A, B, C and D or non-hazardous locations only.***
- B. *WARNING – EXPLOSION HAZARD – Substitution of components may impair suitability for Class I, Division 2.***
- C. *WARNING – EXPLOSION HAZARD – Do not disconnect equipment unless power has been switched off or the area is known to be non-hazardous.***
- D. *All wiring of these devices must be in accordance with the National Electrical Code Article 501.4 (B) for Class I, Division 2.***

3.4 CONNECTORS

Locate and identify Omnii-Comm™ connectors.

3.4.1 9-Pin “D” Connectors

The 266-P00-XYZ Omnii-Comm™ can be ordered with from 2 to 5 serial communication ports. The ports are identified as P1 through P5. The photograph at right shows the Connector Panel for the Omnii-Comm™ if you order 9-pin “D” connectors (-X1Z) option in the part number option suffix). Connectors P1 through P4 are located on the top of the module as shown. Connector P5 is located on the bottom of the module, opposite Connectors P1 through P4, and is not visible in the picture. Connector P5 is the default configuration connector for this module and is always a 9-pin “D” connector. Connector P5 is where you will need to connect your PC for module configuration.

NOTE: All 266-P00 Omnii-Comm™ modules ship with all physical connectors installed as shown in the photograph at right. Depending on the model number purchased, there will be no electronic circuits connected to the physical connector for serial ports not ordered. The Part Number of the module specifies the number of serial ports that are available (2 through 5).

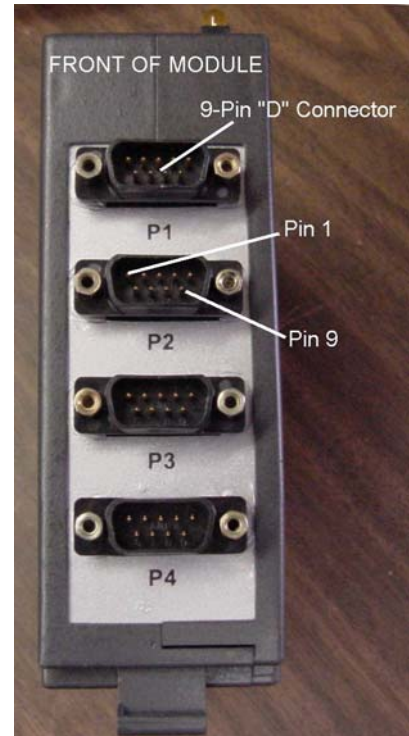

3.4.2 Pluggable Terminal Strips

The 266-P00-XYZ Omnii-Comm™ can also be ordered with pluggable terminal strips in place of the 9-Pin “D” connectors for P1 through P4. To receive this option, enter a “2” in the second position of the options field in the part number (-X2Z). For this option, the connectors are identified as Connector 1 through Connector 4 as shown in the photograph at right. Connectors 1 through 4 are located on the top of the module as shown. Connector P5 is located on the bottom of the module, opposite Connectors 1 through 4, and is not visible in the picture. Connector P5 is the default configuration connector for this module and is always a 9-pin “D” connector. Connector P5 is where you will need to connect your PC for module configuration.

NOTE: All 266-P00 Omnii-Comm™ modules ship with all physical connectors installed as shown in the photograph at right. Depending on the model number purchased, there will be no electronic circuits connected to the physical connector for serial ports not ordered. The Part Number of the module specifies the number of serial ports that are available (2 through 5).

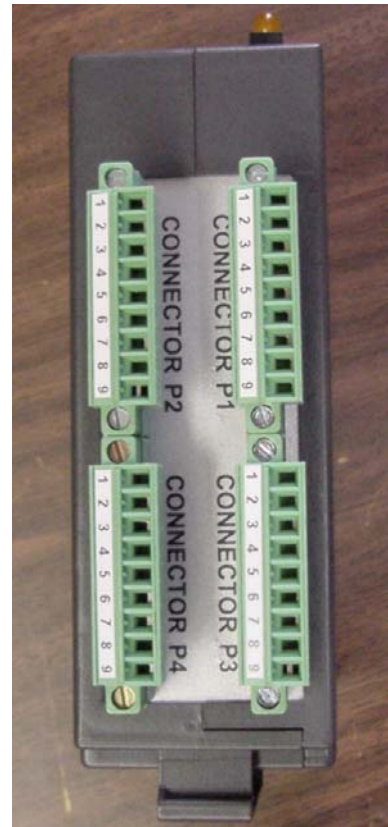

3.4.3 Power and P5 Connectors

The Power and P5 Connector are located on the bottom of the module as shown here. The 9-Pin “D” connector is used for Omnii-Comm™ Configuration and, optionally, as an active protocol port when required. The Configuration connector is ALWAYS set for RS232 operation and ONLY supports modem handshake lines RTS and CTS. The photograph at right shows an AC power connection option (-1YZ).

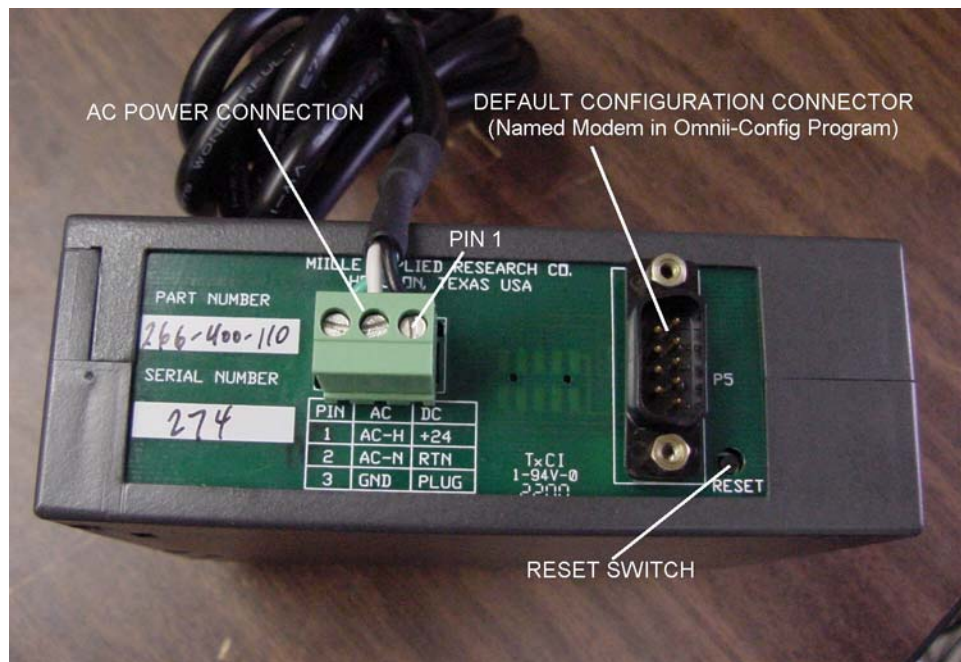

The AC Power Connections are AC-H to Pin 1, AC-N to Pin 2 and AC-GND to Pin 3.

3.4.4 DC Power Connection

This photograph shows the connections for DC operation. The DC + input is on Pin 1 and the DC – input is on pin 2.

3.5 RESET BUTTON

The Reset Button is located just to the lower right of the Default Configuration Connector on both the AC and DC powered versions. Pressing the Reset Button, briefly, forces the Omnii-Comm™ to revert to its “Configuration Mode”.

All normal operation will be suspended and the Default Configuration Connector, in this case the P5 connector, will be reconfigured from whatever it was doing previously to a “Configuration” connector at 9600, 8, N, 1 in preparation for talking with the Omnii-Config™ program.

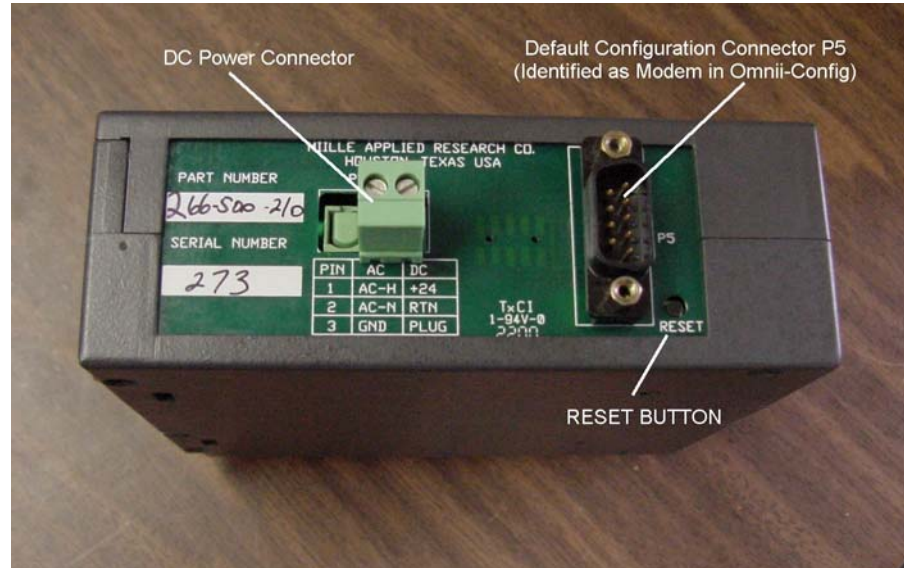

3.6 FRONT PANEL LEDs

The Front Panel LEDs on the Omnii-Comm™ include Transmit and Receive indicators for each port, an Active and an Error light. Some common LED scenarios are listed below:

- ❑ **ACTIVE LED is on steady:** There is no valid configuration loaded.
- ❑ **ACTIVE LED flashes:** There is a configuration loaded, and the unit is attempting to run as configured.
- ❑ **ERROR LED flashes:** There is a system error or poll table error; check the error locations for error codes.
- ❑ **XMIT LED flashes:** The Omnii-Comm™ is transmitting a message from the indicated port.
- ❑ **RECV LED flashes:** The Omnii-Comm™ is receiving a message on the indicated port.

These LEDs help determine connection errors and configuration errors. For example, if the Omnii-Comm™ XMIT light flashes and the RECV light for the same port does not, the cable for that port is either bad or the other device is not responding to the Omnii-Comm™. No response errors are almost always because:

- ❑ **The serial communication parameters don't match (baud rate, # data bits, parity)**
- ❑ **The error check field does not match (CRC, BCC,LRC, etc.)**
- ❑ **The addressed device does not exist**
- ❑ **The Cable Connection is incorrect**

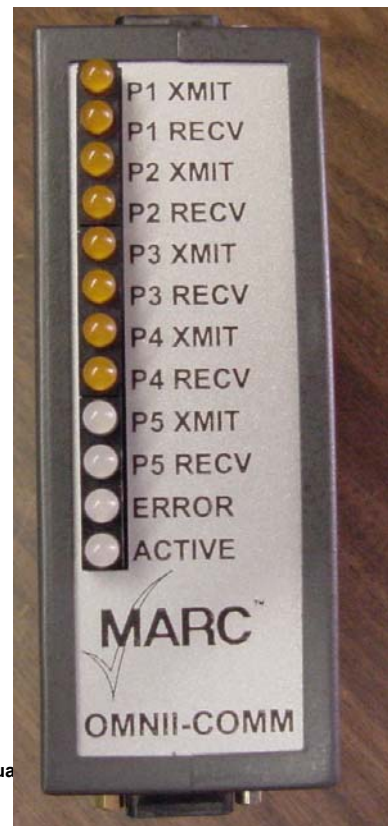

3.7 JUMPER SETTINGS

Connectors P1, P2, P3 and P4 can be configured for RS232, RS422 or RS485 operation. In addition, when selected for RS422 or RS485 there are several additional connector configuration options that are available. You select the communication mode (RS232 or RS422/RS485) and other options by moving jumpers located inside the module case. This section details these jumper options.

Note: The factory default for all connectors is RS232

3.7.1 Opening the Omnii-Comm™ Case

Jumper options are selected by moving shorting pin jumpers located inside the Omnii-Comm™ case. To access these jumpers first open the Omnii-Comm™ case by removing the four screws shown in the photograph at the right.



Separate the case to access the jumper options. The silkscreen on the printed circuit board summarizes the jumper options as detailed in the following paragraphs.

3.7.2 RS232/RS422/RS485 Selection

You configure Connectors P1 through P4 for RS232 or RS422 or RS485 operation by moving the 9-position jumper assembly associated with each connector and located just to the right of the connector as shown in the photo on the right.

The close-up photograph on the left, below, shows connector P1 selected for RS232 operation.

Select RS422 or RS485 operation by simply moving the 9-position jumper assembly associated with the connector from one set of pins to another as shown below on the right. Be sure to add the 10 to 13 jumper as shown in the photograph.

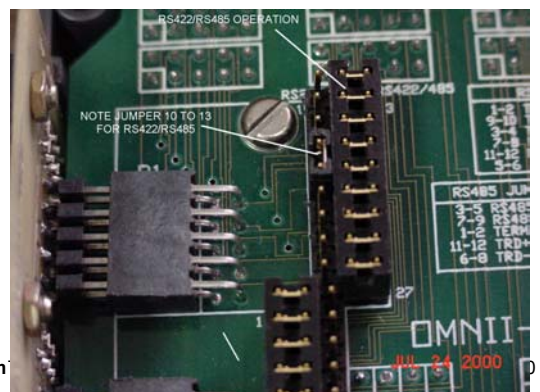
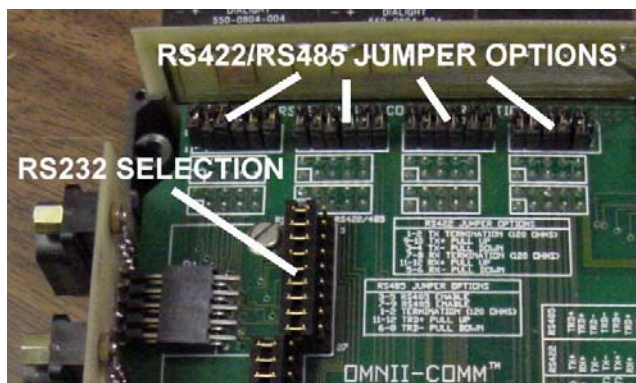
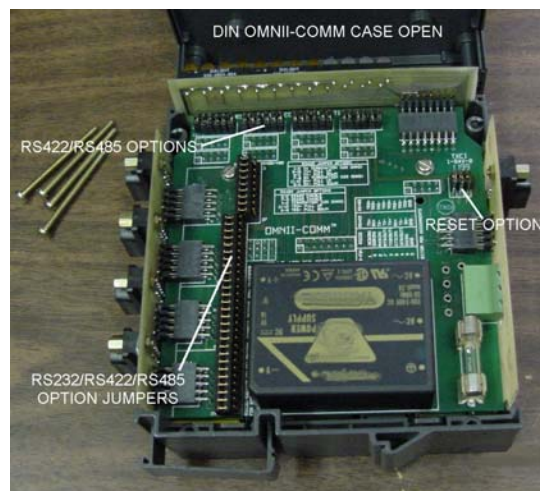

3.7.3 RS422 Jumper Options

When a port is selected for RS422 operation then additional jumper options are enabled. There are 4 sets of jumpers located along the top edge of the card that are used for selection of RS422 and RS485 options as detailed in the following tables. If the Port is selected for RS232 operation then the position of the jumpers does not matter.



Position	Function
1-2	TX Termination Enable (120 ohms)
9-10	TX+ Pull Up (10K to +5V)
3-4	TX- Pull Down (10K to GND)
7-8	RX Termination Enable (120 ohms)
11-12	RX+ Pull Up (10K to +5V)
5-6	RX- Pull Down (10K to GND)

RS422 serial communication uses two twisted pair, one for Transmit and one for Receive. The voltage levels on each pair are differential. The twisted pairs are routed to all devices in a daisy chain fashion. A termination resistor is required at each end of this serial communication line. Pull Up and Pull Down resistors are used to force the differential voltage across each pair to a “marking” or off condition. You only need one Pull Up and one Pull Down resistor somewhere on each pair. Install or remove jumpers as detailed in the table above to select each option.

3.7.4 RS485 Jumper Options

When a port is selected for RS485 operation the jumper options change. There are 4 sets of 6-position jumpers, one set for each connector, located along the top edge of the card that are used for selection of RS485 options as detailed in the following table. If the Port is selected for RS232 operation then the position of the jumpers does not matter.

Position	Function
3-5, 7-9	RS485 Connection
1-2	Termination Enable (120 ohms)
11-12	TRD+ Pull up (10K to +5V)
6-8	TRD- Pull down (10K to Ground)

RS485 serial communication uses a single twisted pair. All Transmitters and Receivers are connected to this pair. The voltage levels on the pair are differential. The twisted pair is routed to all devices in a daisy chain fashion. A termination resistor is required at each end of this serial communication line. Pull Up and Pull Down resistors are used to force the differential voltage across the pair to a “marking” or off condition. You only need one Pull Up and one Pull Down resistor somewhere on the pair. Install or remove jumpers as detailed in the table above to select each option.

3.7.5 Reset Switch Operation

Jumpers J8, J7 and J6 are 3 position jumpers located near the upper right side of the board. J8 is on the left, J7 is in the center and J6 on the right as shown in the photograph to the right. If you jumper 1-2 on J8 as shown in the photograph, then pressing the Reset Switch will force the Omnii-Comm™ to Stop Polling and reset its Default Configuration Connector to a communication mode of 9600, 8, N, 1. This will allow you to gain control of the Omnii-Comm™ in order to be able to download new configurations. An alternative mode of operation for the Reset Switch is possible.

Note: J8 1-2 is the factory default setting

If you move J8 to the 2-3 position (not shown), then pressing the Reset Switch will have an entirely different affect. If J8 is in the 2-3 position, then pressing the Reset Switch will cause the Omnii-Comm™ to perform the same actions that it would on a power up cycle. This usually is a cold start. All RAM memory will be cleared, Power On Self Tests will be run, the Log-on messages will be sent out and polling will be started. The Configuration mode will NOT BE ENTERED.

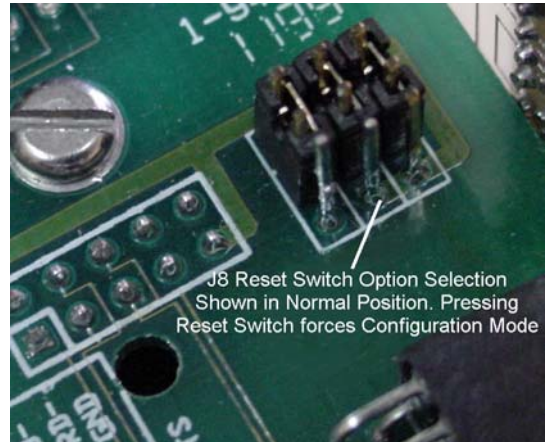

3.8 CONNECTOR PIN OUTS

The 266-P00-XYZ Omnii-Comm™ has two, user selectable, connections for the first four connectors (P1 through P4) on the module. They may be either 9-Pin “D” connectors or “Pluggable” terminal strips.

Connector P5 is always a RS232, 9-Pin “D” Connector. Connector P5 only supports the TXD, RXD, RTS, CTS and GND signals. The remaining pins on P5 are not connected. The following pin assignments apply to all other connectors of the MARC 266-P00-XYZ Omnii-Comm™:

3.8.1 9-Pin “D” Serial Port Connector Pin Assignments

The following table presents the pin connections when the Omnii-Comm™ is equipped with 9-pin “D” connectors (Option 1).

Pin #	RS232 Name	RS422 Name(P1-P4)	RS485 Name (P1-P4)
1	DCD (input)	TX+	TRD+
2	RXD (input)	TX-	TRD-
3	TXD (output)	TX+	TRD+
4	DTR (output)	TX-	TRD-
5	GND	GND	GND
6	DSR (input)	RX+	TRD+
7	RTS (output)	RX-	TRD-
8	CTS (input)	RX+	TRD+
9	RI (input)	RX-	TRD-

Typical Omnii-Comm™ to RS232 device using 9-pin connectors on both ends. The connections shown on this cable drawing make up a “null modem” connection.

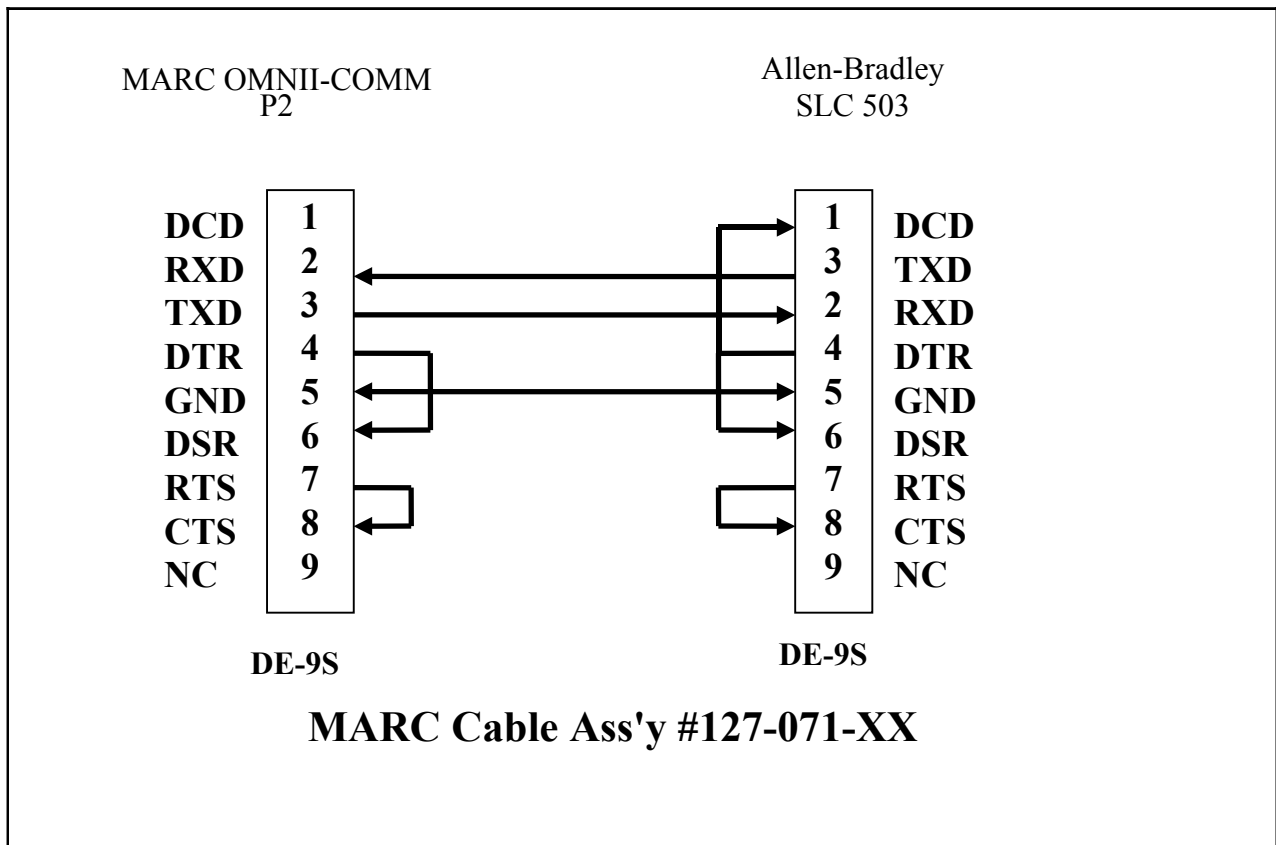

3.8.2 “Pluggable” Serial Port Terminal Strip Pin Assignments

The following table presents the pin connections when the Omnii-Comm™ is equipped with Pluggable Terminal Strips (Option 2). The terminal strip assignments are for Connectors 1 through 4 only. Connector P5 is always a 9-pin “D” connector and the pin assignments are as shown in section 3.5.1 above.

Pin #	RS232 Name	RS422 Name	RS485 Name
1	DCD (input)	TX+	TRD+
2	DSR (input)	RX+	TRD+
3	RXD (input)	TX-	TRD-
4	RTS (output)	RX-	TRD-
5	TXD (output)	TX+	TRD+
6	CTS (input)	RX+	TRD+
7	DTR (output)	TX-	TRD-
8	RI (input)	RX-	TRD-
9	GND	GND	GND

Typical Terminal Strip to 9-pin RS232 connector cable. Pin connections shown are for a typical Null modem connection.

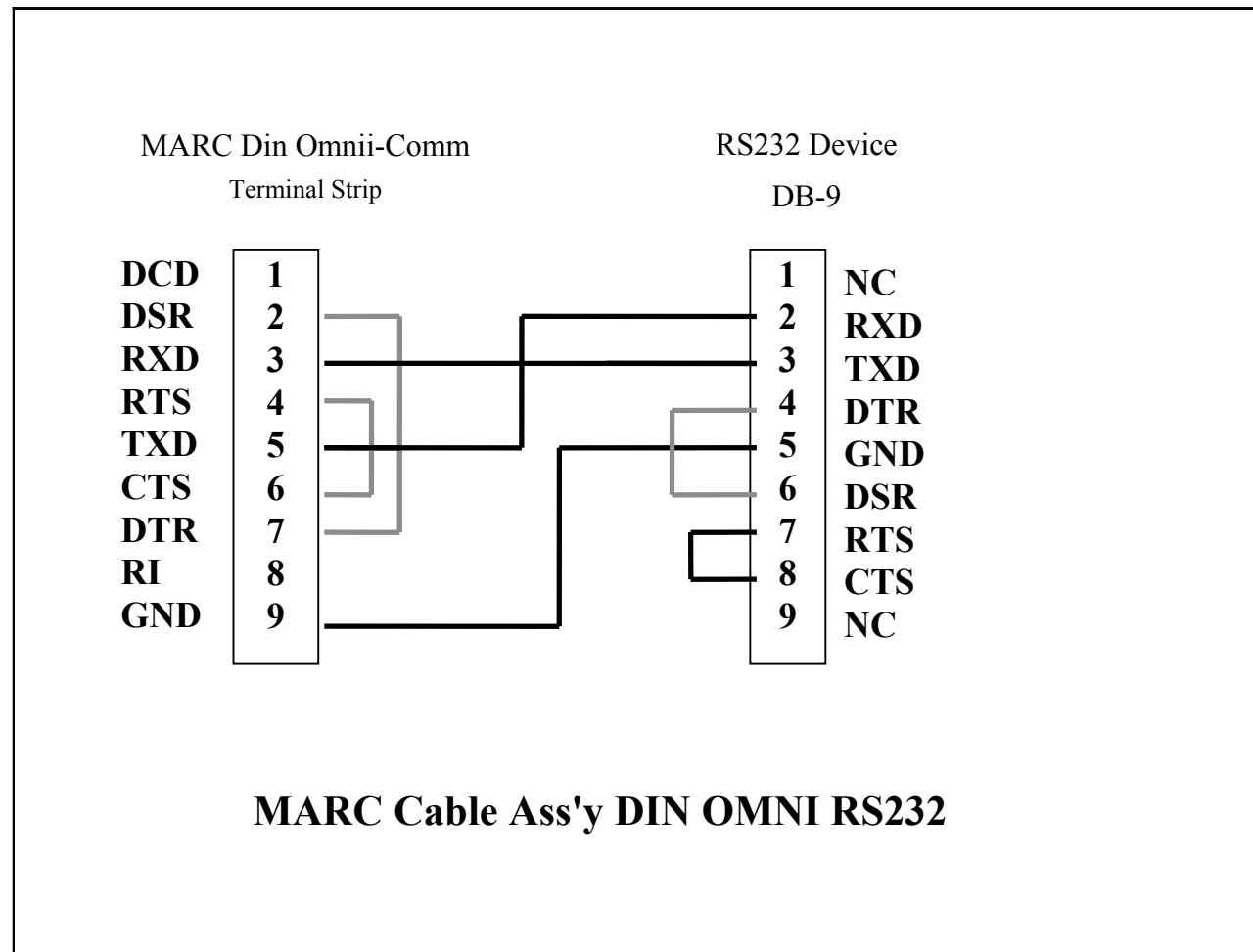

CONFIGURATION

4.1 GETTING STARTED

Omnii-Comm™ operation is completely defined by user configuration files that you must generate using the Omnii-Config™ program and then download to the Omnii-Comm™ using a serial port on your PC. A Configuration Program, Omnii-Config™ is supplied with each Omnii-Comm™ module. If the CD is missing you may download the latest copy of Omnii-Config™ from our web site at <http://www.miille.com>. You can also download a set of example configuration files if you wish.

4.2 SYSTEM REQUIREMENTS

You need the following software and hardware to install and run Omnii-Config™:

- Microsoft Windows 95/98/ME/2000/XP or NT 4.0 or later Operating System**
- A CD ROM Drive**
- Mouse or other pointing device**
- 800 x 600 VGA video display (minimum)**
- 32 megabytes (MB) or RAM (minimum)**

4.3 INSTALLING OMNII-CONFIG™

A setup program guides you through the Omnii-Config™ installation process. The program transfers files from the CD to a folder that it creates on your hard disk. The program also creates a menu item on the Windows Start Menu.

If a version of Omnii-Config™ already exists on your hard drive you must remove it first before installing the new version. The setup program will detect the existing version and prompt you to remove it. After the program has been removed rerun the setup program to install Omnii-Config™.

Installation starts automatically after you insert the Omnii-Config™ CD into your CD-ROM drive. If installation does not start, you can install Omnii-Config™ by using the following procedure.

1. Insert the Omnii-Config compact disc into your CD-ROM drive.
2. Wait for the autorun feature to start, or choose **Start > Run**.
3. In the **Open Field**, type `d:\setup`, where *d* is the letter assigned to your CD-ROM drive.
4. Click OK and follow the instructions on your screen.

4.4 UNINSTALLING OMNII-CONFIG

1. From the **Start** menu select **Settings**, and then **Control Panel** and **Add/Remove programs**.
2. Select **Omnii-Config** from the list and click the **Add/Remove** button (Windows 95/98/ME/NT) or the **Change/Remove** button (Windows 2000/XP).
3. Follow the on-screen instructions.

4.5 STARTING OMNII-CONFIG

To start Omnii-Config, choose Start > Programs > Omnii-Config > Omnii-Config for Windows.

If you use Omnii-Config frequently you may wish to create a shortcut to it on your desktop.

When you start Omnii-Config, the program opens a new blank configuration file that is based on a default configuration file, Default.DBA. You can load and edit Default.DBA just as you can any other configuration file.

The Omnii-Config program should start and you should see the Main Edit screen.

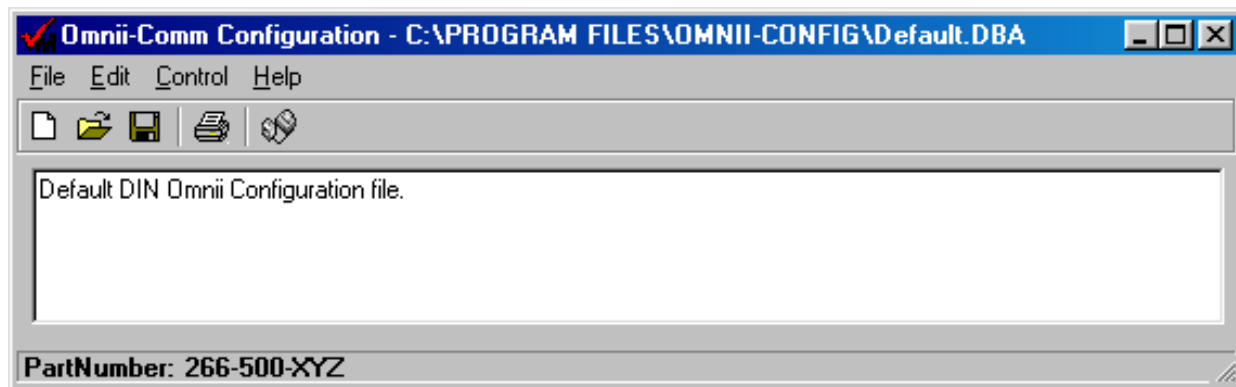

The text box in the center is a place for you to enter descriptive text that is pertinent to the application where the Omnii-Comm™ is being used. This is stored along with the configuration file and will be displayed anytime that the configuration file is loaded in the future. Also note the Part Number at the bottom of the screen. Configurations are built for specific Omnii-Comm™ part numbers. It is important that you have the proper part number selected before you start the configuration process. If the part number in the Default.DBA file is not correct, change it by selecting Edit > Change Part Number and selecting the correct part number from the dropdown list.

4.6 BASIC PROCEDURE

There are only three basic steps required to build a configuration file and you will start each one of them from the Main Edit screen shown above.

4.6.1 The three basic steps are:

- Configure the connectors**
- Configure common items**
- Define address mapping between protocols**

Once you have built a configuration file, you will save it using the Save or Save As commands under the File menu item. You will use the Control menu item to download the configuration file to the Omnii-Comm, save it to non-volatile memory and to Start Polling on the Omnii-Comm™. You can click on the Help menu item at any time to get on-screen help.

Depending on your specific application and the protocols to be used, it is not possible to provide an exact step-by-step procedure that can be used in all cases. The following paragraphs present a typical configuration that can be used as a starting place for your final configuration. If you understand the example configuration, you should have no problems editing it to match your exact requirements

4.7 EDIT/CONNECTOR

The first step in a configuration process is to configure the connectors. You can define the protocol to use on each Omnii-Comm™ connector in almost any way you want! Be aware that there are some minor restrictions and caveats that we will address later in this section but for now, just assume that you can assign any protocol to any connector.

From the Main Edit screen select Edit then Connector

The Connector Selections screen will appear.

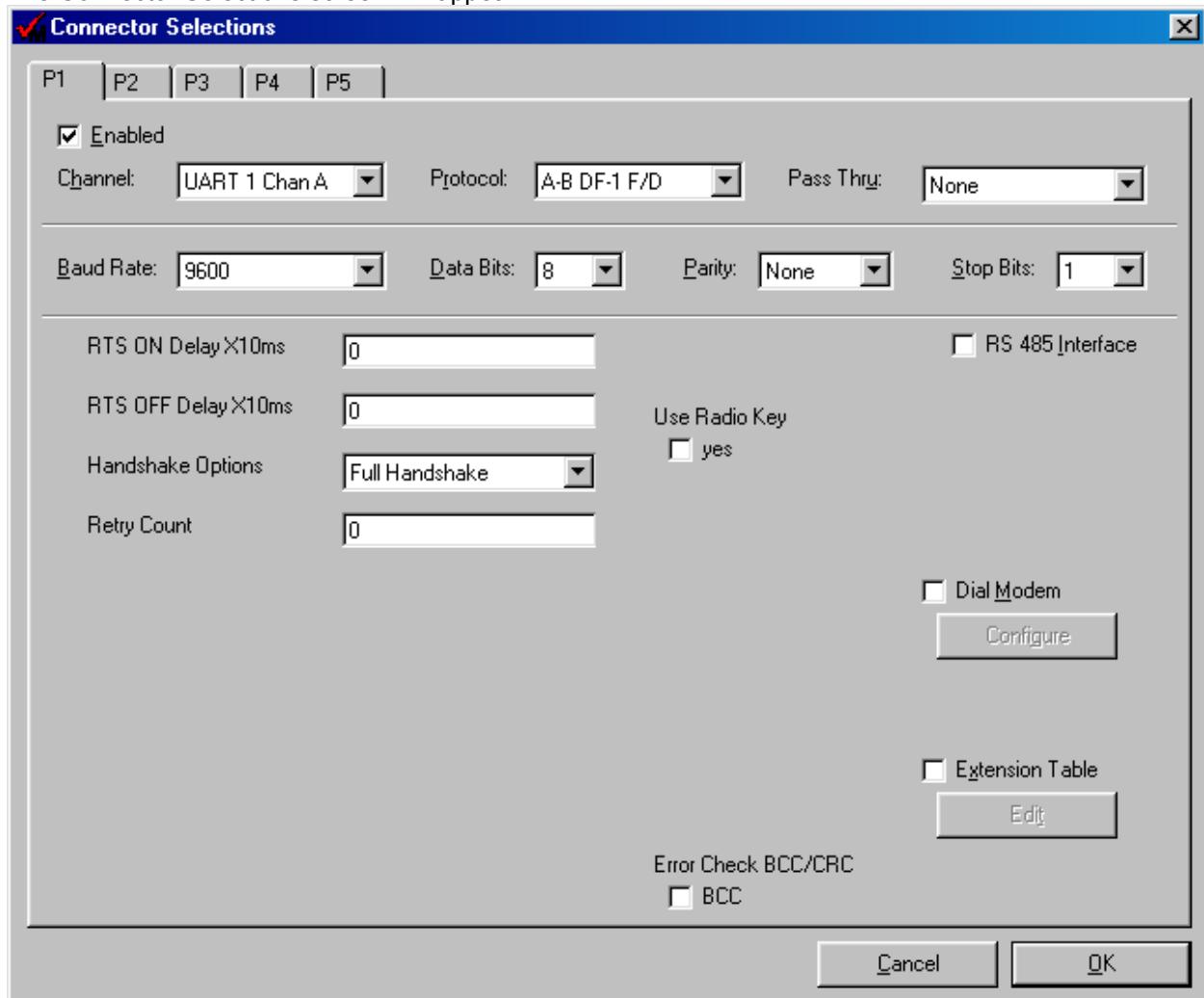

Select the connector to configure by clicking on the tab at the top. Depending on the model number you have selected, you will have a different number of connector tabs. If you want to use this connector the Enabled box should be checked. If you do not want to use the connector, clear the Enabled box.

NOTE: If you select the wrong part number, it is possible to configure connectors that do not exist on the target Omnii-Comm™ hardware. If you configure a connector that is not available, then you will get an error when you attempt to run the configuration (start polling).

For each connector (P1, P2, P3, P4 and P5) select the protocol you wish to assign and a “Channel” to use for it. Channel assignments are unique; you can only use a channel name on a single connector. If you try to assign the same channel name to two different connectors, you will get an error message when you attempt to save the screen. Note that when you select a different Protocol, you will be presented with additional choices on the Connector Selection screen that are appropriate for the protocol selected.

Think of the “Channel” as a communication resource such as COM1, COM2, etc., on your PC. The Omnii-Comm™ has several “Channels” and each provide different features. Some protocols require a specific “Channel” to be selected for operation. If this is the case, it will be noted in the help files for that specific protocol.

One of the connectors on every Omnii-Comm™ is designated as a “Configuration” connector. This is the connector to which the PC is connected, enabling you to download a new configuration file. You can FORCE an Omnii-Comm™ to go to its configuration mode and reconfigure its Configuration connector for download by pressing the RESET button on the module. In all current Omnii-Comm™ models, the “Configuration” connector is either P1 or P5. The DIN rail Omnii-Comm™ described in this manual ALWAYS uses the P5 Connector as its default configuration connector.

You should factor the Default Configuration connector into your connector assignment selections. It is very convenient to configure the Default Configuration connector (P1 or P5) with the Configuration protocol when you set up the module. This will leave the Configuration connector active when you start the module and provide a “window” into the module for debugging. If you need it, you can configure the Default Configuration Connector as another protocol port at run time by simply re-defining it in your configuration program.

Again, you are free to choose the protocol for each connector depending on your system constraints.

After you have configured all of the connectors, save the information by pressing the OK button.

The following paragraphs detail the common Connector Selections screen fields. Other fields may be present depending on the protocol selected. Refer to the on-screen help files for details on these fields.

4.8 EDIT/GENERAL

From the Main Edit screen select Edit then General

The General configuration screen will appear. This screen is where you will enter information that is common to all ports on the Omnii-Comm™.

The Omnii-Comm™ Database organization is selected as Modbus in this example. The RTU address field is used to set Modbus Slave Address we will respond to when polled by a Modbus Master. In this case, we are Modbus Address 5. The Omnii-Comm™ Address is selected to be 9. The Poll Timer Multiplier is set to 1. The Radio Key Address is not used in this application so it is set to 0. The Operating MODE is selected to be Normal with no Virtual RTU support. The Error Time Out is set to 5 seconds. We are not going to use the Dynamic Poll Table Timers so the data type field is set to Not Used. The following paragraphs provide additional detail for the the General Configuration options:

4.8.1 Edit/General/Database Protocol

The Omnii-Comm™ has a large amount of internal RAM storage that can be utilized in many applications for collecting and organizing data. IF YOU HAVE A SLAVE PORT, then you use the Database Protocol selection to define how the internal memory space of the Omnii-Comm™ will be organized for your particular application. If the Omnii-Comm™ will be a Modbus Slave device, then you will want to organize the data space as if it were a Modbus Device. If you want the Omnii-Comm™ to appear as an Allen-Bradley PLC, then you would want the Omnii-Comm™ to appear as an Allen-Bradley PLC. Set this entry to match the protocol type you want Slave Ports on the Omnii-Comm™ to emulate. You can only organize the database in one way.

4.8.2 Edit/General/RTU Address

This is the address that the Omnii-Comm™ will respond to if a port is configured for slave operation.

4.8.3 Edit/General/Omnii-Comm™ Address

Some protocols require that the SENDER of a message insert its own address into the "Source" field of all messages that are originated by that device. Allen-Bradley DF-1 protocol messages have both a Source Address and a Destination Address field in the message. This field is used to define the address that the Omnii-Comm™ will use in the Source Address field.

4.8.4 Edit/General/Poll Timer Multiplier

Polling Tables are used to define the movement of data in an Omnii-Comm™ system as detailed in the following section. Each poll table has a Repeat Timer associated with it that defines how often the Omnii-Comm™ is to attempt to execute the poll. The timer value is entered as some number of 10msec “ticks” since the basic unit of timing in the Omnii-Comm™ is a 10msec clock. The largest number that you can enter in the Timer Repeat Value field is 65,535. Thus, the maximum polling interval is 655,350 milliseconds or about 11 minutes. If you need longer polling intervals, then the poll table timer “tick” value can be increased by the number entered in the Poll Timer Multiplier field. For example, entering a value of 100 would make the “tick” value 100 X 10msec or 1 second. A poll table repeat value of 3,600 would then define a poll that would run once per hour.

4.8.5 Edit/General/Radio Key Address

Some Omnii-Comm™ products are used with radio communication networks. Some radios require a contact closure to “key” the radio transmitter (turn on the transmitter). This is commonly called a PTT (Push To Talk) input. If the modem used with the Omnii-Comm™ does NOT HAVE a PTT output (most of our modems have a PTT) then some other device must be used to “key” the radio. If the Omnii-Comm™ is connected to a PLC then a spare contact output of the PLC could be used as the PTT input for the radio. The value entered into the Radio Key Address field will define a register in the PLC that will be written to when the Omnii-Comm™ needs to send a message. When the message has been sent, the register will be accessed again to turn off the PTT bit. The PTT bit is the LEAST SIGNIFICANT BIT in the register. The other address parameters required for defining exactly where this register is located, such as PLC address and file type, are read from the “System Error” location that is defined from the Main Poll Table Selection screen that is described in the next section.

4.8.6 Edit/General/Mode

Currently there are 2 “modes” of operation for an Omnii-Comm™. They are: Normal and Return Last Data

The Normal and Return Last Data modes define how the Omnii-Comm™ SLAVE port will respond when it receives a request for information that is not valid in the database. The “quality” of all data points in an Omnii-Comm™ database is monitored continuously. If, for some reason, the database is not updated as defined in the Polling Tables, then the “quality” of the data is defined to be “bad”. If the database has been refreshed from the last Polling Table then the data quality is “good”. If the Mode is set to Normal, then the Omnii-Comm™ will respond to a request for data that has been marked “bad”, i.e. not refreshed in the manner defined for the particular protocol that is in use. For example, if the request came from a Modbus master to read some registers that had not been refreshed, then the response would be a Modbus error code “Failure In Associated Device”. No data would be returned. Setting the Mode to Return Last Data would instruct the Omnii-Comm™ to return the “Last” data collected. This might be only a few seconds old or possibly several hours or even days old data.

CAUTION: If Return Last Data mode of operation is selected, then it is very important that the master continuously monitor the Poll Table Error locations to determine if the data being returned is valid or not.

4.8.7 Edit/General/VRTU Equipped™

The VRTU (Virtual RTU) Yes or No modes determine if the Omnii-Comm™ will have “Virtual RTUs” or not. Normally, the Omnii-Comm™ will respond to only a single RTU address, the one defined in the RTU Address field. In some large systems, it is desirable to have the Omnii-Comm™ respond to several RTU

addresses. Selecting Yes for this option will instruct the Omnii-Comm™ to read a “VRTU Definition File” to obtain the addresses and configuration information for each “Virtual RTU”. Currently, only the CA, CPASR3 and CPASR4 protocols recognize the VRTU option. The complete description of Virtual RTU configuration is beyond the scope of this manual. See the VRTU application note for further descriptions of Virtual RTU configurations.

4.8.8 Edit/General/Timer Table Type

As described earlier in Section 4.8.4, Polling Tables are executed periodically based on a Poll Table Repeat timer value that is defined when each polling table is configured. The Timer Table Type field on the General Screen allows the user to optionally define a “data type” (area in the Omnii-Comm™ Database) that can be used to provide the Poll Table Repeat timer values. If the Timer Table Type is set to Type 00 or Not Used then the repeat values configured in the Polling Tables are used to schedule the Poll Table operation. If any other Type is selected, then the Omnii-Comm™ will retrieve the repeat values from the Data type specified and use it instead of the values configured in the Polling Table. This provides a convenient way for the user to dynamically alter the Polling Table repeat rates. Polls can be turned off by setting the repeat value to 0. Setting the value to non-zero will restart the poll. If the database is filled with data read from a block of integer registers in a PLC, then the polling rates can be easily changed simply by changing the integer numbers in the PLC. Poll Time Out values are fixed by the values defined in the polling tables.

4.8.9 Edit/General/Error Time Out

Polling tables have a “Poll Table Repeat Timer” that determine the frequency of each polling table. When the action defined in the Polling Table Read or Write sections cannot be performed within the “Poll Table Time Out” period a time out error occurs. The poll can be optionally retried depending on the Retry setting on the Connector Screen. If it still fails, then the failing poll will be removed from the active list of polls for a period of time entered in this field. This time is measured in seconds. An entry of 60 would result in a retry 1 minute after the poll failed. If the poll succeeds, then it is placed back into the current list and repeated at the defined Poll Table Repeat interval. If it fails, then it will be retried later. This improves the polling update rate for other polls because failed polls are not retried until after the Error Time Out.

4.9 EDIT/POLL TABLE

From the Main Edit screen select Edit then Poll Tables

The Poll Table Selection screen will appear. Polling tables are where the bulk of the work in an Omnii-Comm™ application takes place. We will review the poll tables for a typical application in detail. First, take a close look at the Poll Table Selection screen. There is a lot of information displayed for you to use.

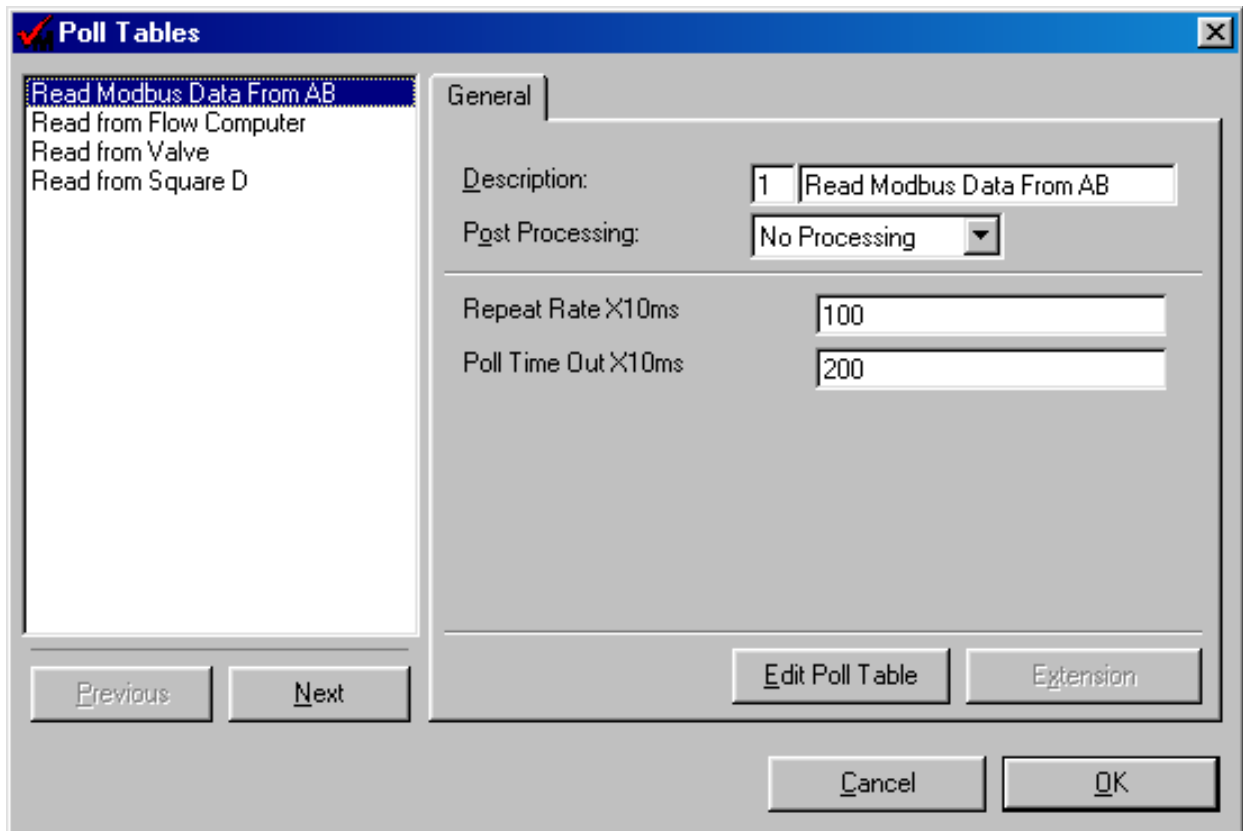

First, you can see that this configuration has 4 tables. The Poll Table Descriptions are displayed on the left portion of the screen. Table number 1 is the Current Poll number because it is highlighted in the Table Description window. You can make another table the current one by simply clicking on the description for the table you want to see. You can edit the description by selecting a poll table (Click on the description) and then editing the text in the Description field on the upper right. Post Processing operation is shown in the Post Processing window and the Repeat Rate and Poll Time Outs are also shown for the Current Poll. They may be changed at any time.

There are four buttons on the Poll Tables window that are used for editing and navigation. Clicking on the Edit Poll Table button will open the Poll Table Edit screens for the Current Poll. Previous and Next can be used to step forward or backwards thru the list of poll tables. If the Edit Poll Table window is not open, clicking on Previous or Next will move Current Poll Table selection and open the Poll Table Edit screen. If the Poll Table Edit window is already open, then Previous and Next show the contents of the selected poll table Read, Write or Error section that was previously selected. This provides a convenient way to cycle thru the poll tables to review their settings.

The Extension button will be active if the selected polling table references the database. The extension table is used to define how data collected by a Poll Table Read operation will be stored in the database.

Poll Tables can be easily added, deleted and rearranged as necessary. Pressing the Insert key on your keyboard will make a copy of the Current Poll Table and place it at the end of the list. Pressing the Delete key will remove the Current Poll Table. You can also Right Click in the Description Window and select Insert or Delete to perform the same functions.

You can rearrange the order of the polling tables by first selecting a poll table (Click on the description) then Right Click and select Move Up or Move Down. The order of the poll tables is important because that determines the order in which the Database locations are filled. The order can be easily changed using the Move Up and Move Down functions. The Move Up function “bubbles” the current table number up one position; Move Down does the opposite.

4.9.1 Poll Table #1; Read Modbus Data from AB

On the Poll Tables screen make Table #1 the Current Poll number by Clicking on the Read Modbus Data from AB Description. Then click the Edit Poll Table button

Before we dive into the specifics for this poll table there are some general items that are important to note. First, every polling table has three sections:

- ❑ **Read section that tells the Omnii-Comm™ how to go about collecting some data**
- ❑ **Write section that tells us what to do with the data collected in the Read section.**
- ❑ **Error section that tells us what to do in case we have problems with either the Read or the Write operation.**

Polling tables that Write to the Omnii-Comm™ Database also have an “Extension” table that tells us how to sort the incoming data into the Database. The sections are accessed by clicking on the Read, Write and Error tabs. The Current Poll Table Number and Description is shown for reference at the top of the Poll Table Edit screen. Shown at the bottom of the screen is the Channel and Protocol that will be used for the operation. Remember, the Channel is uniquely assigned to a specific Connector on the Connector Configuration screens that were completed earlier. The first thing to define on any poll table selection screen is the Connector to use for the operation that you want to perform.

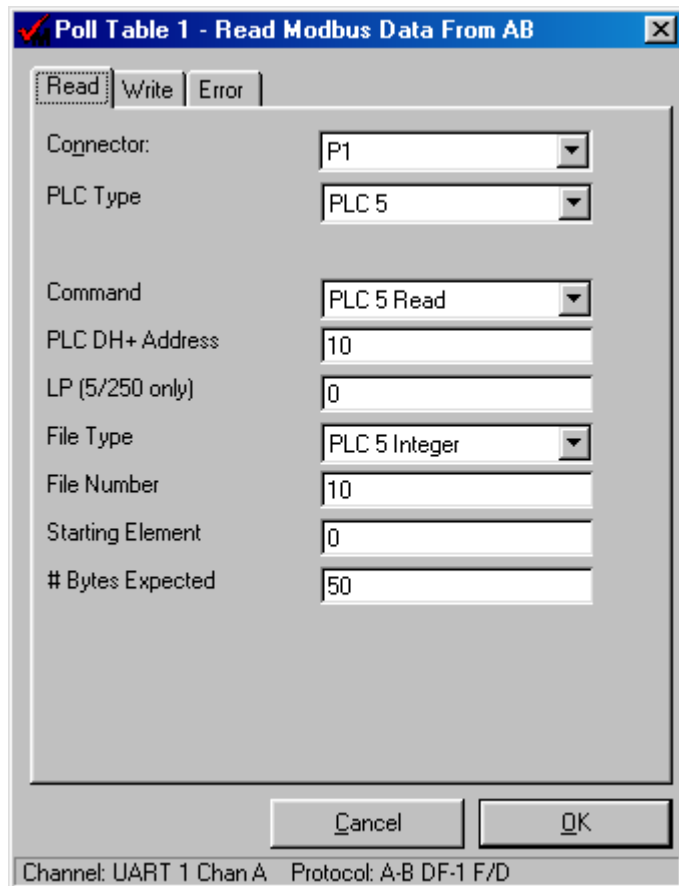

NOTE: The Omnii-Comm™ has two “pseudo” connectors that can be enabled. They function like a real hardware connector but do not actually occupy any hardware resources. They only support one protocol each and the protocol cannot be changed. They are called Local RAM (VRAM) and Database. You enable and disable VRAM and Database by clicking on the Enable RAM and Enable Database entries on the Edit menu. The functions are enabled if a small check appears to the left of the selection.

Poll Table #1, Read

The Read section of Polling Table 1 is automatically opened when you click on the Poll Table button on the Main Poll Table Selection screen or when you click on the Read tab.

The connector selected is P1 which is configured for Allen-Bradley DF-1 Full Duplex protocol (see Section 4.7). The rest of the items on this screen tell the Omnii-Comm™ how to go about reading some data from an Allen-Bradley PLC that is connected to P1 using the DF-1 Full Duplex protocol. This table reads 25 Integer Registers (50 bytes) from a PLC 5, Integer File 10 starting with Element 0. The Data Highway address of this PLC is 10.

Note that the Data Highway Address entered on this screen is a DECIMAL number. Data Highway Addresses in an Allen-Bradley PLC 5 system are usually numbered in OCTAL. You will need to convert the Octal Data Highway Address into a decimal number before you enter it here. Decimal 10 is Data Highway address 12 octal.

The Poll Table Write section, explained next will define what we will do with this data.

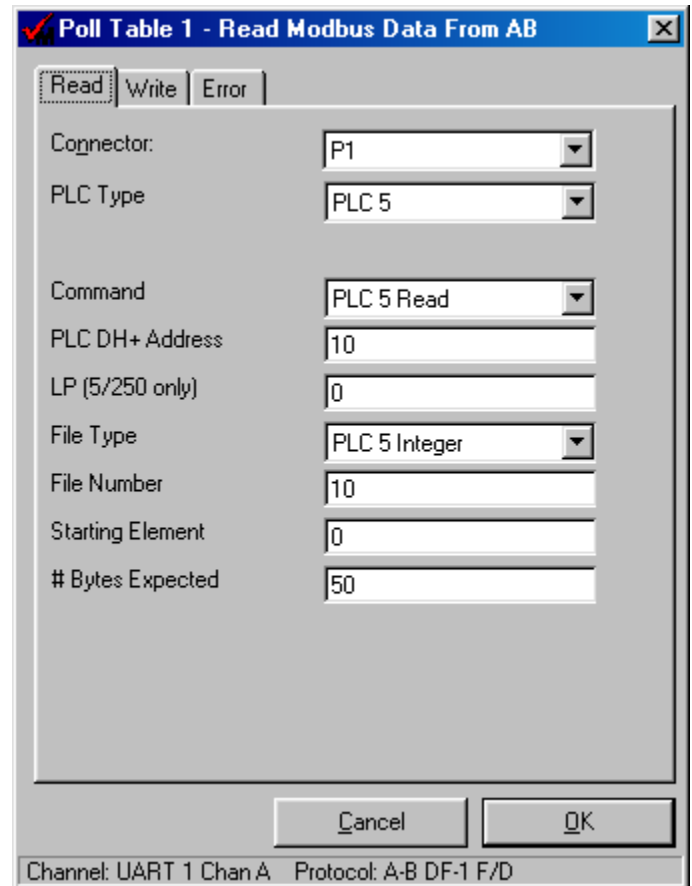

Poll Table #1, Write

Clicking on the Write tab opens the Write section of Poll Table #1.

The Connector selected for the Write operation is Data Base so the important information will be contained in the Extension Table. Click on the Extension button to see the Database Extension Table as shown below.

The Database Extension Table is used to define how to distribute the data from the read operation into the Database of the Omnii-Comm™. We have selected Modbus on the Header screen as our database type so we have Modbus data types to select from. The

Extension Table says that we are to create 2 Status Cards (32 Input Status Bits), 5 Input Registers, 32 Coils, and 16 Holding Registers from the 50 bytes of data we got from the read section. This example shows that you can read multiple data types with a single read. It may be convenient to define multiple poll tables to fill the database. Status Inputs from one area in the PLC, Input Registers from another, Coils from another, etc. Reading them all in at one time is more efficient but does require that all the data be moved into file N10 in the correct order by the ladder logic. This may make it more difficult to expand the number of points should you need to do so in the future unless you provide spare points when you first define your PLC memory layout.

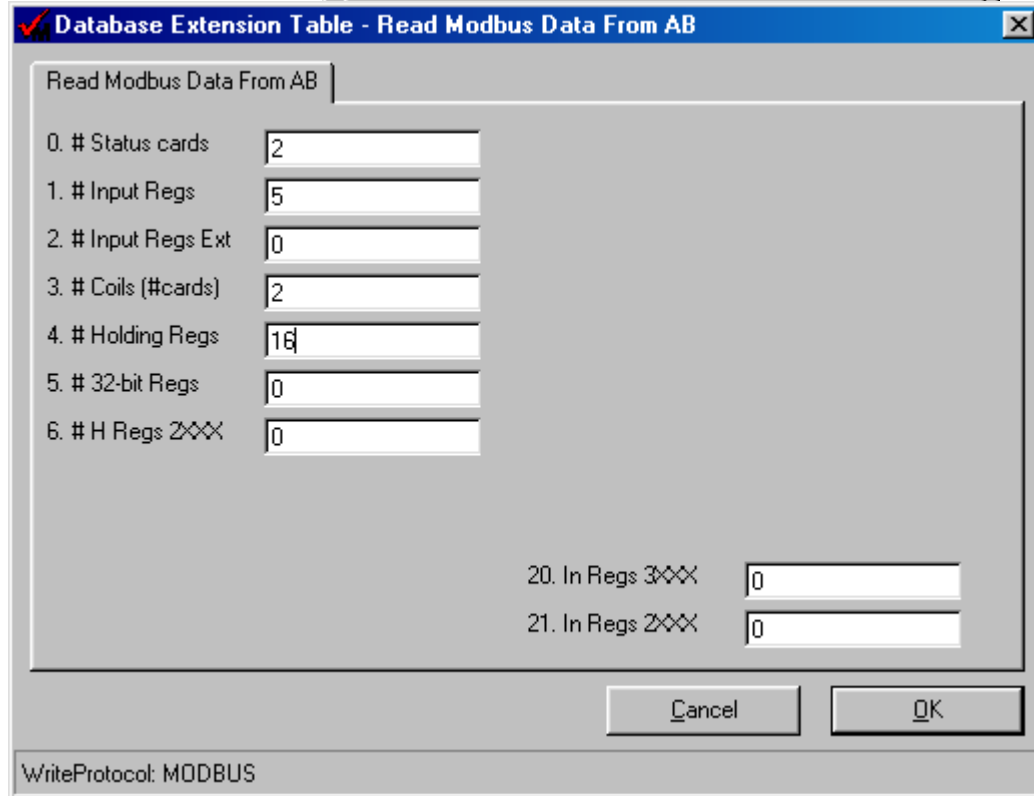
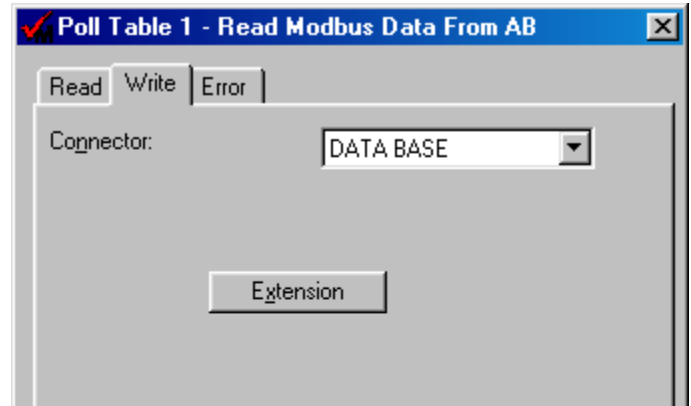

Note: NO PLC PROGRAMMING is required to set up the Omnii-Comm™ Database. If data is scattered about the PLC, you can simply define more polling tables to collect it. Read one register from here, one from there until you have it all collected. You can define up to 140 polling tables (up to 80 with Database Extension Tables)

Poll Table #1, Error

Clicking on the Error tab opens the Error section of Poll Table #1.

The Error word associated with Poll Table 1 is N12:1 in the Allen-Bradley PLC 5. The Omnii-Comm™ will write an error to this register if an error occurs while it is attempting to execute the Read and Write sections if Poll Table #1. All error writes are one word (2 bytes) long. You can of course change this register number as required for your application

4.10 SAVE CONFIGURATION

Add poll tables as required to completely map all information as required by your application and then return to the Main Edit Screen and select Save or Save As under the File Menu item. Saving the file automatically creates two files: a download file, **filename.S19** and the configuration file, **filename.DBA**.

Filename.DBA file is what you will reload into Omnii-Config to make configuration changes.

Filename.S19 is a hex coded file that is downloaded to the Omnii-Comm™ to define its operation.

You Open and Edit a .DBA file with Omnii-Config and Download a .S19 file to the Omnii-Comm™ using the Control menu selection as described in the following section.

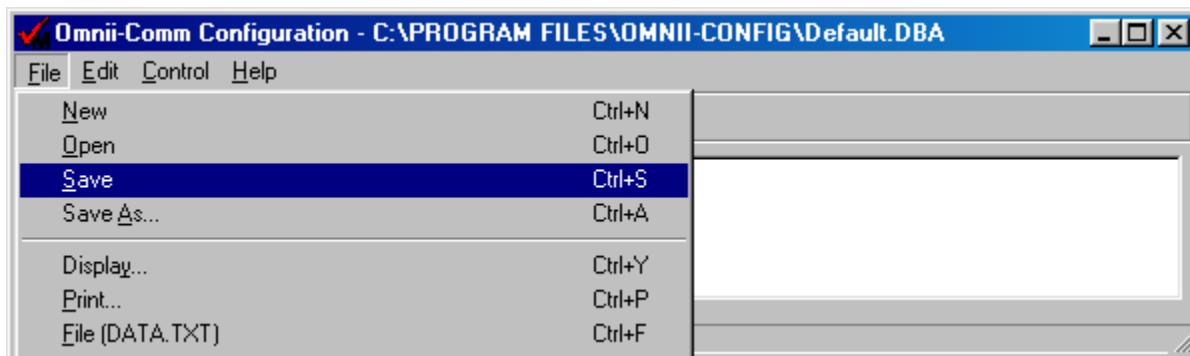
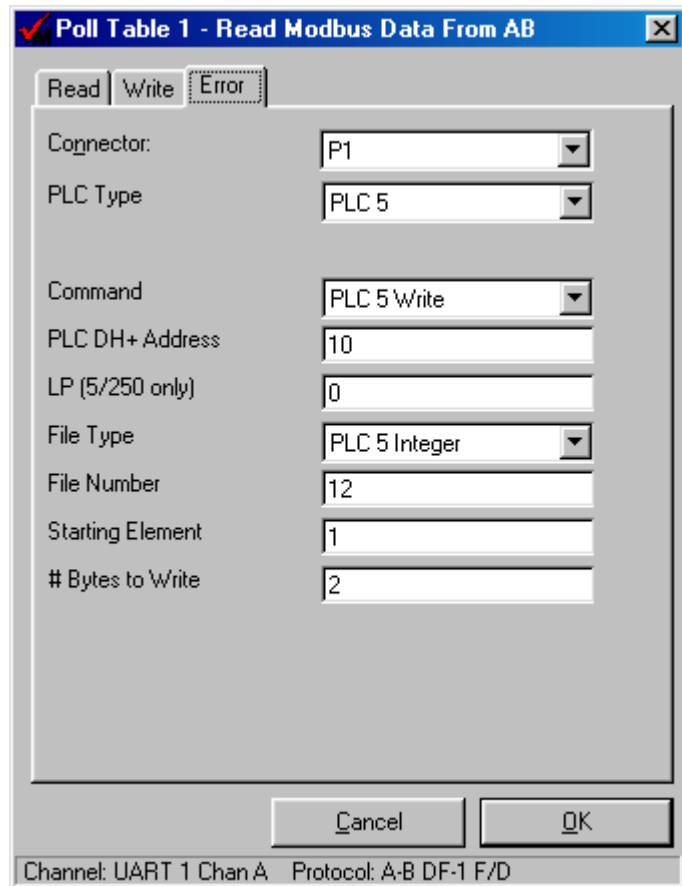

4.12 CONFIGURATION DOWNLOAD

From the main edit screen select Control then Communications

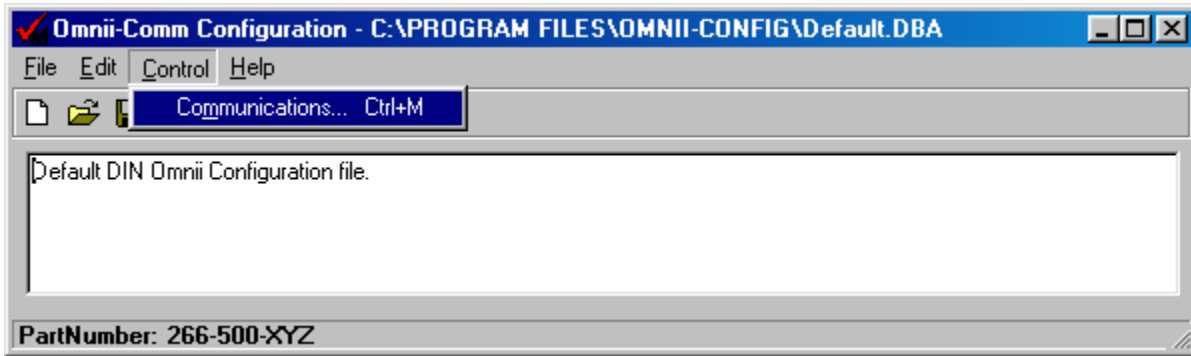

This screen warns you to save your configuration changes

NOTE: If you just did a Save or Save As you don't need to do it again.

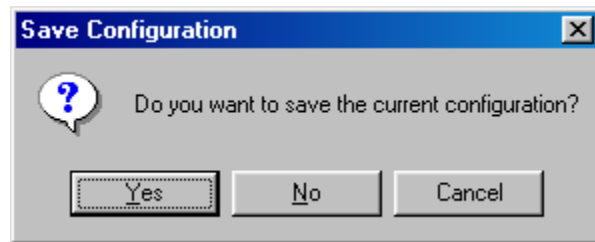

If you click Yes, then the current configuration will be saved to *filename.DBA* where *filename* is the name of the currently open file. Clicking No opens the Communications screen without saving the configuration first. Clicking Cancel takes you back to the Main Edit Screen.

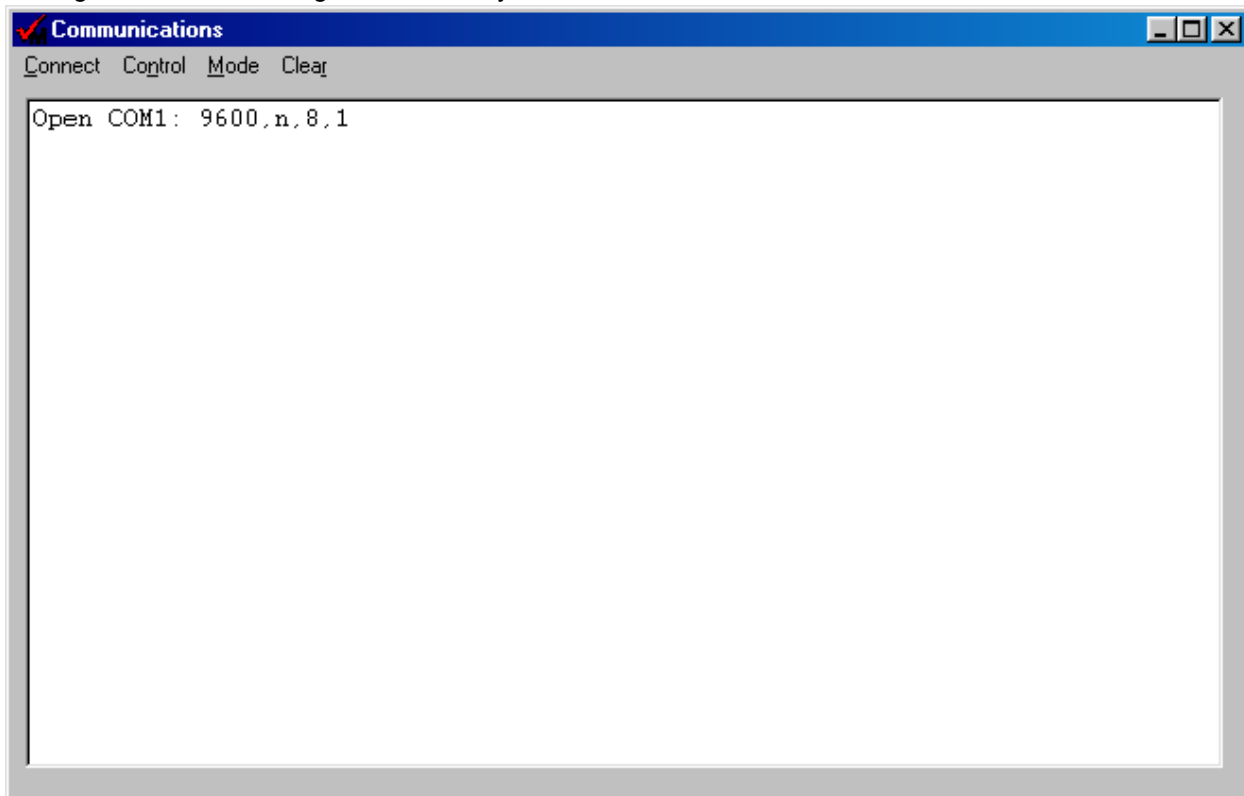

4.12.1 Connect/Check Connectivity

Clicking on the Connect Menu item on the Communications screen provides four options as shown below. Check Connectivity verifies that the PC and the Omnii-Comm™ can communicate. A carriage return is sent to the Omnii-Comm™ when you click on Check Connectivity or press F8 on the keyboard. The Omnii-Comm™ should return an Omnii-Comm™ prompt each time the Check Connectivity function is executed. You can save the contents of the Communications screen by clicking on Save to File or pressing F2 on your keyboard. Close ends the Communications screen and returns you to the Main Edit menu.

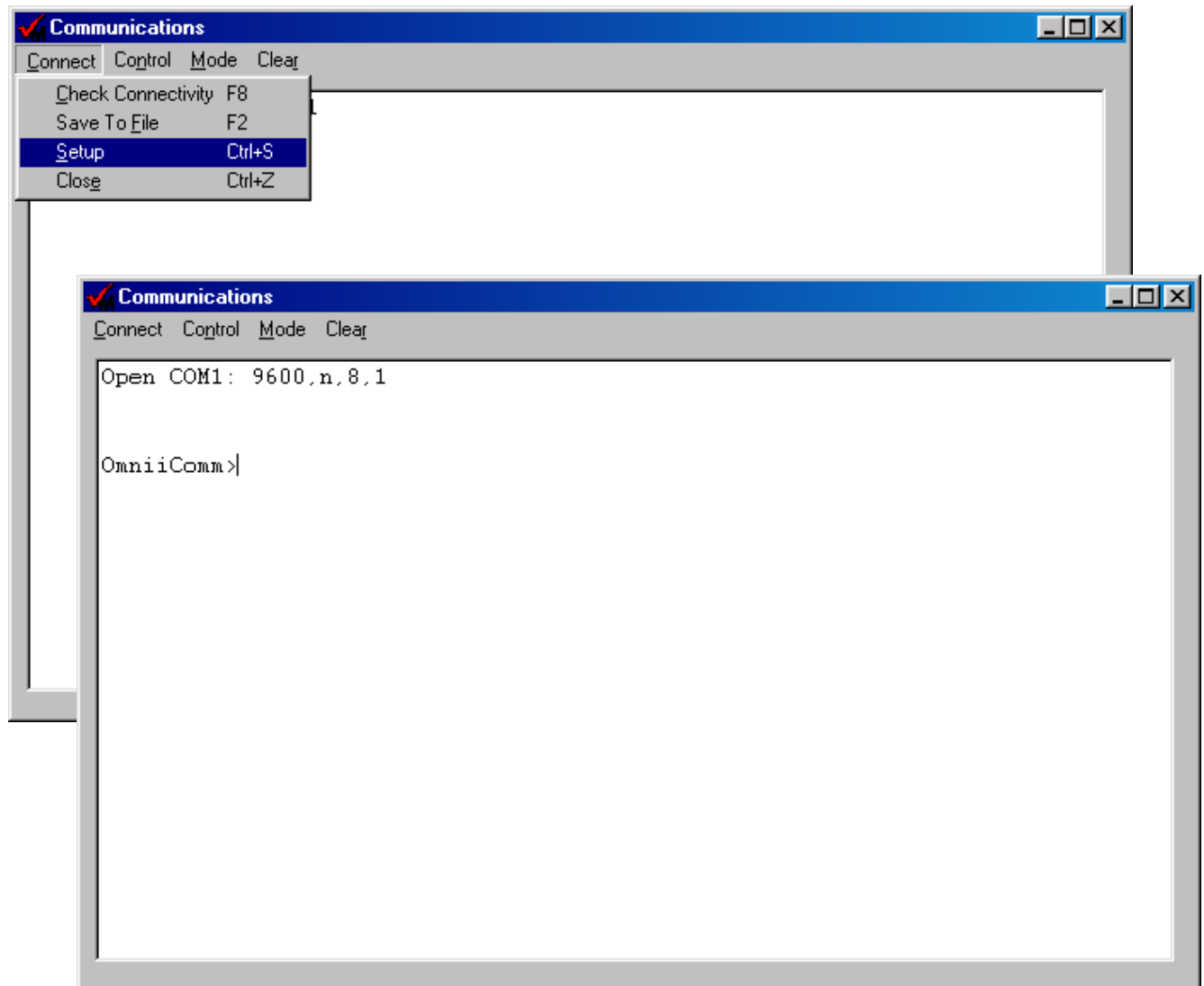

4.12.2 Connect/Setup

Selecting Connect/Setup will open the Setup Options screen.

Select the PC Communications port you want to use from the Connect Using dropdown list. You can edit the download serial port settings for Baud Rate, Data Bits, Parity and Stop Bits from this screen for special applications. Normally, the default settings of 9600, 8, None and 1 should be used.

RAM Start Address, RAM End Address, EEPROM Start Address and # Bytes to Transfer are options that will allow Omnii-Config to be used with all models of the Omnii-Comm™. Current DIN rail Omnii-Comm™ models will use the settings shown at the right.

Older DIN rail Omnii-Comm™ models will use an EEPROM Start Address of F800 and the # Bytes to Transfer to 7CF. Some existing applications may also need to have the RAM Start address set to 7000. Contact MARC Technical Support if you have any questions about these settings.

The S19 File to be downloaded is automatically selected when you did a File Save or Save As from the Main Edit screen. Click on the button to browse to select a different file. Normally, you will not need to change this selection.

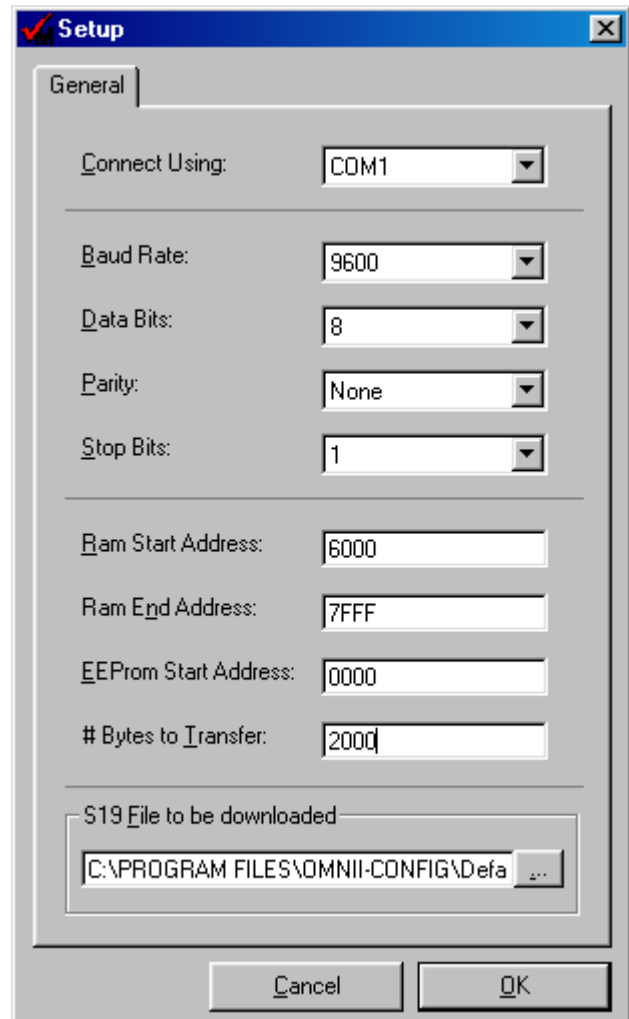

4.12.3 Control

Clicking on the Control menu item shows the various fixed functions that are available from the Communications screen. Many other functions can be performed thru the serial port for diagnostics and troubleshooting communication and configuration problems. The fixed functions are normally all that are required.

You may need to manually stop the Omnii-Comm™ and make P5 ready to communicate with the Control messages before clicking on any of the Control options. This would be required if the Omnii-Comm™ was previously running and connector P5 was not configured as a Configuration connector or if for some reason the Omnii-Comm™ program is not running correctly. To force Connector P5 into the configuration mode, press the Reset Button (located on the bottom of the module near the P5 connector) briefly. The Omnii-Comm™ should stop polling, reconfigure P5 and be ready to accept commands from the Control function. You only need to press the button for a brief time. Holding the button down for more than a second will cause a Watch Dog Timer error to occur and the Omnii-Comm™ may restart instead of going to the Configuration Mode.

Note: The description above applies only if the Reset Switch Operation described in Section 3.6 has not been changed from its factory default. If this jumper has been moved, then pressing the Reset Button will Restart the Omnii-Comm™ and P5 will be reset to whatever the loaded configuration file defines.

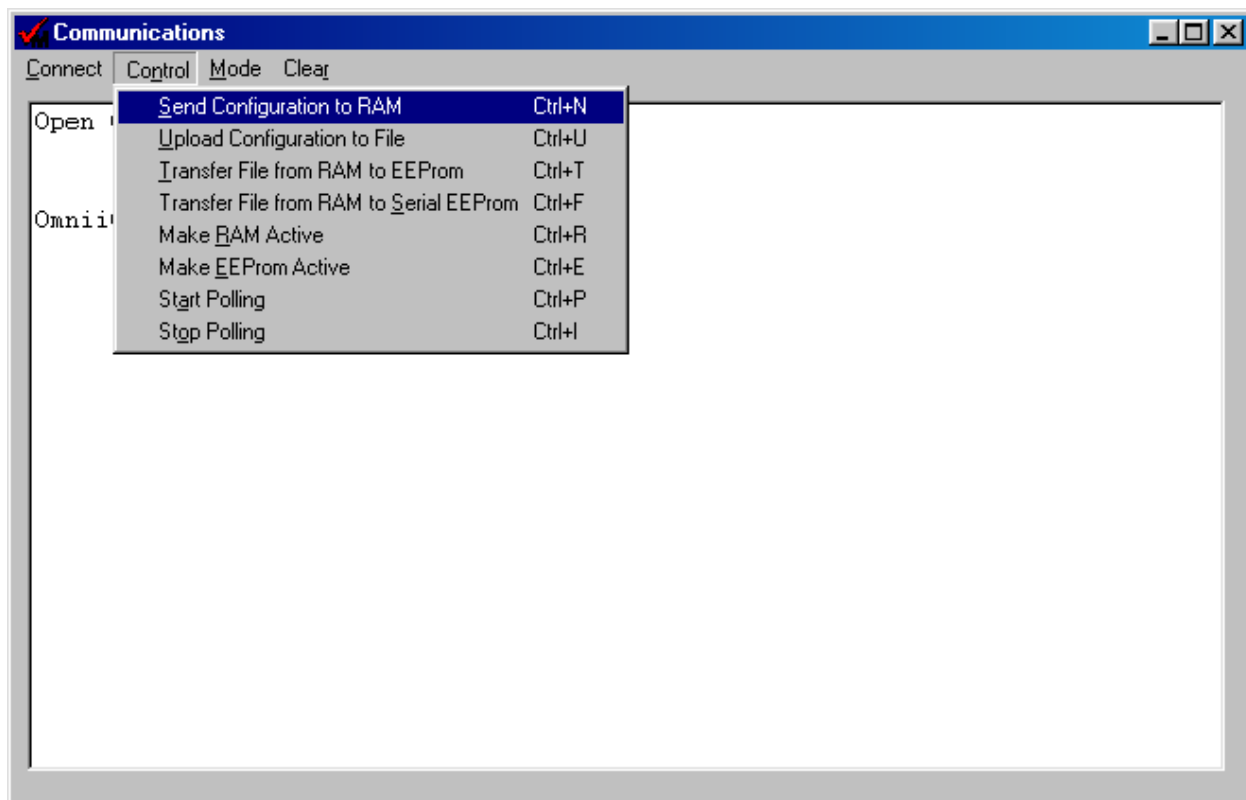

You can verify that the Omnii-Comm™ is ready to accept the Control commands using the Check Connectivity function described earlier. Press F8; If you are connected properly and the Omnii-Comm™ is ready to accept configuration commands you should see the Omnii-Comm™ prompt

Omnii-Comm>

each time you press the F8 key.

If you do not see the Omnii-Comm™ prompt, then either the P5 Connector is not configured to accept Control Commands, the cable is incorrect or your PC has a problem with serial port communication. One common problem occurs when you are in a Windows environment and have another program running that is also trying to use your serial port. You can only have one program in control at a time so the other program will need to be shut down in order for Omnii-Config to gain control of the serial port.

4.12.3.1 Send Configuration to RAM

Clicking on Send Configuration to RAM will transfer the current configuration file to RAM memory on the Omnii-Comm™. A Stop Polling command will be sent prior to sending the file to the Omnii-Comm™. You should see the contents of the .S19 download file scroll by on the screen as each line is sent. After the file has been sent, the Omnii-Comm™ is interrogated and the currently active configuration will be reported.

Note: Configuration files are always downloaded to RAM. You must select Move to EEPROM or Move to Serial EEPROM from the Control menu to save to non-volatile memory and then select Make EEPROM active.

Note: We recommend that you always test your configurations while running in RAM by selecting Make RAM Active. Transfer to non-volatile memory only after everything is working.

4.12.3.2 Upload Configuration to File

Clicking on Upload Configuration to File will transfer the currently active configuration to a disk file on your hard drive. You will be prompted for a path and file name. A DBA file will be built using the uploaded .S19 file so you can edit an existing configuration even if you do not have the original .DBA file. The currently active configuration is determined by the last Make RAM Active or Make EEPROM Active Control received.

Note: Poll Table Descriptions and the module Part Number are not stored in the downloaded configuration file so they will not be reconstructed.

4.12.3.3 Transfer File from RAM to EEPROM

This function moves the contents of RAM to EEPROM memory. EEPROM memory is non-volatile memory available on some models of the Omnii-Comm™. If it exists, the allowable address range for storing a configuration is between F800h and FFCFh. These addresses (start address and length) should be entered on the Connect/Setup screen prior to doing the transfer. If EEPROM is not available, an error message will be returned from the Omnii-Comm™ and displayed on the screen.

4.12.3.4 Transfer File from RAM to Serial EEPROM

This function moves the contents of RAM to Serial EEPROM memory. Serial EEPROM memory is non volatile memory available on most new models of Omnii-Comm™. If it exists, the allowable address range for storing a configuration is between 0000h and 2000h. These addresses (start address and length) should be entered on the Connect/Setup screen prior to doing the transfer. If Serial EEPROM is not available, an error message will be returned from the Omnii-Comm™ and displayed on the screen.

4.12.3.5 Make RAM Active

Use this function to run the configuration currently in RAM.

Note: Select Make RAM Active if you have stored your configuration in Serial EEPROM. The contents of the Serial EEPROM are copied from the Serial EEPROM to RAM on startup.

4.12.3.6 Make EEPROM Active

Use this function to run the configuration currently in EEPROM.

4.12.3.7 Start Polling

Starts the Omnii-Comm™ operation. The Active light should start blinking at a steady rate.

4.12.3.8 Stop Polling

Suspend Omnii-Comm™ operation. The Active light will continue to blink.

4.12.4 Mode

Selecting the Mode menu option alternately enables and disables "Terminal Emulator" mode. When Terminal Emulator mode is on, all keystrokes typed on your PC keyboard are sent to the Omnii-Comm™. Responses from the Omnii-Comm™ will be shown in the Communication window. This mode of operation is used for advanced debugging and troubleshooting under the direction of MARC Technical Support only. When the Terminal Emulator mode is active, the Control menu items are not available.

4.12.5 Clear

Selecting the Clear menu option will erase the contents of the Communications window.

OMNII-COMM™ TROUBLE SHOOTING TIPS

5.1 PROBLEMS & SOLUTIONS

1. Problem - The Omnii-Comm™ does not respond with the Omnii-Comm™ prompt when the Connect/Check Connectivity option or the F8 key is pressed

Solution- The cable from the P.C. to Omnii-Comm™ Port 5 is not a null modem cable or the small black reset button on the Omnii-Comm™ was not pressed before the download attempt. It may help to cycle power on the Omnii-Comm™ and attempt downloading again. Make sure that RAM is active.

2. Problem - A “Start Poll” command is issued and the Active/On Line LED will not flash and the Error LED turns on.

Solution - There is a **fatal** configuration error in the Omnii-Comm™ configuration file. Make sure that the following are consistent between the Omnii-Comm™ and the devices it communicates with: error checking (CRC, BCC), baud rate, data bits, stop bits, parity, protocol, signal specification (RS-232, RS-422/485), etc. Make sure that the configuration program is saved correctly before downloading. Check error locations for error codes.

3. Problem - The Omnii-Comm™ starts to poll, but immediately turns on the Error LED, and there is no further polling activity from a port for up to 30 seconds, then another poll attempt is made and the same thing happens again.

Solution - There is a **minor** configuration error in the configuration file, or possibly a minor hardware problem such as a bad cable. Make sure that the configuration program is saved correctly. Make sure to use the correct cable, and that the cable is installed properly. Check to see if the Omnii-Comm™ and other devices in the system have valid addresses, and that there are no address conflicts. Check error locations for error codes.

4. Problem - The Omnii-Comm™ seems (by watching the TXD and RXD LEDs on the Omnii-Comm) to transmit a message to another device, but the other device does not respond back, or it responds with a message that the Omnii-Comm™ does not understand.

Solution - Similar solutions as to Number 3 above. This usually indicates a cable problem or an addressing problem. Also make sure that baud rates, signal specifications (RS-232, RS-422/485), etc., are the same between the Omnii-Comm™ and the devices to which it is connected. Make sure to issue valid commands to the Omnii-Comm™ and to other devices in the system. Check error locations for error codes.

ERROR CODE DEFINITIONS

6.1 OBJECTIVES

Errors can occur for many reasons as the Omnii-Comm™ goes about its communication chores. Transient events may inject noise on the communication lines and a CRC error will be detected. Someone may accidentally disconnect a cable and we will be unable to talk with some device. Buffers may overflow, power may go out of specification and many other problems may occur. When an error occurs, the Omnii-Comm™ will attempt to write an error code to an error location. If the error can be associated with a polling table, then it will be written to the Poll Tables Error Location. If the error cannot be associated with a specific poll, then the error will be written to the System Error Location. Error codes are all 2 byte, Hexadecimal Coded numbers.

This section describes the error codes used by the Omnii-Comm™.

6.2 GENERAL INFORMATION

Error codes are stored as Hexadecimal words in the error locations defined by the configuration program (poll table & system error locations). If the error code originates from the Omnii-Comm, the high byte of the error word indicates the **PROTOCOL** of the communication link that has an error, and the low byte indicates the **SPECIFIC ERROR** that is occurring. If an error is being reported by a device that is connected to the Omnii-Comm, the high byte will have its most significant bit set and the error code returned from the device will be placed in the low byte. **Example:** Error code 0BF5h indicates that there is an error with Modbus communication, and there is no response from the remote unit within the configured time-out period. Error code 8B02h on the other hand is an error reported to us from the Modbus device (the most significant bit is set in the high byte) and the Modbus error that is reported is 02, which is an invalid address error.

To decode an Omnii-Comm™ error code you will need to know two things: the Protocol Number and the Error Code. Use the following tables to decode Omnii-Comm™ errors. Remember, if the high bit of the most significant byte is set, then the error code is from the device we are connected to. They do not come from this table.

6.3 PROTOCOL NUMBERS

The following table defines the protocol numbers in the Omnii-Comm™.

Decimal	Hex	Protocol Name
08	08	Local RAM
09	09	Dial-Up Modem
10	0A	Database
11	0B	Modbus (ASCII and RTU)
12	0C	Allen-Bradley DF-1 Full Duplex
13	0D	Square D (Point-to-Point and Multi-Drop)
14	0E	MARC Protocol
15	0F	Teledyne CA and CA Report by Exception, not CA CPASR
16	10	Debug (Configuration)
17	11	Reliance
18	12	Allen-Bradley DF-1 Half-Duplex
19	13	OMRON Hostlink
20	14	PML 3720
21	15	American Dynamics 2150
22	16	Dukane MACS II
23	17	Caterpillar M50
24	18	Dynalco TM5000
25	19	Dynalco TEC 9000
26	1A	Caterpillar Digital Voltage Regulator (DVR)
27	1B	Conitel 2020 Slave
28	1C	TEJAS Slave
29	1D	GE Programmable Lighting
30	1E	Modbus Report By Exception
31	1F	DANLOAD 6000
32	20	ASCII
33	21	Controlotron
34	22	Tennessee Gas Pipeline
35	23	Data Aire
36	24	Liebert
37	25	CDC 44-560 (Type II)
38	26	Multiport Monitor
39	27	Sutron
40	28	SCI CSNET
41	29	Sullair Supervisor II
42	2A	Brite (BIF)
43	2B	AMOCAMS 500
44	2C	Toshiba
45	2D	HSQ
46	2E	Colonial DLE
47	2F	CA CPASR (4-byte Meters)
48	30	Quantum
49	31	CA Master
50	32	Sullair Supervisor IE

6.4 OMNII-COMM™ ERROR CODES

The following tables define the Omnii-Comm™ error codes. There is a separate table for each number series.

6.4.1 Error Codes 10 – 1F Table Initialization Errors

10	Illegal mode in Header table
11	Too many poll tables
12	Illegal RTU type in poll table
13	Illegal PLC type in poll table
14	Different RTU types within poll table
15	Wrong protocol selected
16	Illegal RTU count
17	Too many points configured
18	Invalid info in poll table
19	Read table byte count not equal to Write table byte count
1A	RAM error during active RAM test
1B	Invalid port number
1C	Error in XDETECT Database
1D	SETCMD buffer full
1E	Gate array does not support requested function
1F	Attempt to write across 2 poll tables

6.4.2 Error Codes 20 – 2F Spurious Interrupt Errors

20	SPI
21	Pulse Accumulator Input Edge
22	Pulse Accumulator Overflow
23	Timer Overflow
24	Timer Output Compare 4
25	Timer Output Compare 3
26	Timer Output Compare 2
27	Timer Output Compare 1
28	Timer Input Capture 3
29	Timer Input Capture 2
2A	Timer Input Capture 1
2B	Real Time Clock
2C	XIRQ
2D	Illegal Op code
2E	COP Fail
2F	COP Clock Fail

6.4.3 Error Codes 30 –3F Port/Driver Initialization Errors

30	Illegal Port
31	Illegal Protocol
32	Error in Serial Port Configuration
33	Wrong Port or Connector defined
34	No protocol defined for port
35	Illegal parsing instruction
36	Protocol Extension Table not defined
37	Data size is not 2 or 4 bytes per element
38	Error in Virtual RTU initialization table
39	Illegal Parsing Table
3A	Bad Separator in Parsed String
3B	Max Message too Small (CA)
3C	Unsupported Baud Rate
3D	Invalid RTU Address
3E	Not Used
3F	Not Used

6.4.4 Error Codes 40 –4F Modem Errors

40	Invalid response from modem
41	Insufficient data in modem response
42	Modem type not recognized
43	Init string invalid or too long
44	Not Used
45	Not Used
46	Not Used
47	Not Used
48	Not Used
49	Not Used
4A	Not Used
4B	Not Used
4C	Not Used
4D	Not Used
4E	Not Used
4F	Not Used

6.4.5 Error Codes 50 – 5F Miscellaneous Errors

00	Watch dog timer disabled
01	Error in TIMEOUT program
02	Caterpillar Auto init failure
03	Error in state byte
04	Bad data for XDETECT command flag/data
05	Queue empty
06	Post Process procedure error
07	RTU Off Line
08	Wrong message type (Pass Thru)
09	Momentary Control Point >500
0A	Queue Full
0B	COS Buffer Full
0C	Illegal RAM Page
0D	Not Used
0E	Not Used
0F	Not Used

6.4.6 Error Codes 70 – 7F Driver I/O Errors

70	SIO Parity, overrun or framing error
71	CRC error
72	Received byte error count
73	Receiver buffer overrun
74	Transmitter buffer overflow
75	Illegal control code in received data
76	Illegal character in received message
77	Illegal PLC address in received message
78	Error in receiver state byte
79	Error in transmitter state byte
7A	Error in timer state byte
7B	Error in received data
7C	SQD Link not established
7D	Illegal command
7E	Bad data returned
7F	No data to return

6.4.7 Error Codes 80 –8F Floating Point Errors

80	Floating point overflow error
81	Floating point underflow error
82	Not Used
83	Not Used
84	Not Used
85	Divide by 0 error
86	Number too large or too small to convert to integer
87	Attempt to take square root of negative number
88	TANGent of 90 degrees attempted
89	LOG or LN of negative number or 0
8A	ARC COS not implemented
8B	ARC SIN not implemented
8C	Floating point format error in ASCII to FLOAT routing
8D	Not Used
8E	Not Used
8F	Not Used

6.4.8 Error Codes F0 - FF System Errors

F0	Stack Error in TASKER
F1	Illegal command in BLDCMD
F2	Transmitter buffer full
F3	Transmitter pointer queue full
F4	Insufficient data returned from poll
F5	No response from remote within timeout
F6	Unable to send, no CTS from port
F7	Invalid state found in PTSTATE
F8	Error in RTU message
F9	Bad address in BLDCMD
FA	Bad pointer in OUTQUE
FB	CA download error in BLDCMD
FC	Modbus Command Queue full
FD	Conitel MCD state error
FE	Bad pointer (RWEPTR, PCB, etc.)
FF	CMDBUFFER Full

Error codes not defined in the tables above are not used at this time and are reserved for future use.

Notes

Notes

NOTES

**CONTACT OUR SALES OFFICE FOR ADDITIONAL INFORMATION ON
OUR OTHER PLC COMMUNICATIONS PRODUCTS**

LEASED LINE MODEMS

FOR PLC 5 AND SLC 500

DIAL UP MODEMS

FOR PLC 5 AND SLC 500

COMM-MASTER™

PLC 5 POLLING MASTER CARD

COMM-TROLLER™

PLC 5 PROTOCOL CONVERTER

OMNII-COMM™

UNIVERSAL COMMUNICATIONS CONTROLLER

FOR PLC5 AND SLC 500

MILLE APPLIED RESEARCH CO., INC.

P.O. BOX 87634

HOUSTON, TEXAS 77287

USA

VOICE 800/729-0818

OR

FAX 713/472-0318

Come visit us on the web at

<http://www.mille.com/>